

Features

- Wide 3.3V to 16V Operating input Range
- 2A Continuous Output Current
- No Schottky Diode Required
- 600KHz Frequency Operation
- Built-in Over Current Limit
- Built-in Over Voltage Protection
- Internal Soft start
- Output Adjustable from 0.6V
- Integrated internal compensation
- Short Protection with Hiccup-Mode
- Thermal Shutdown
- Available in SOT23-6 ,Package
- -40°C to +85°C Temperature Range

Applications

- Digital Set-top Box (STB)
- Tablet Personal Computer (Pad)
- Flat-Panel Television and Monitor
- Digital Video Recorder (DVR)
- Portable Media Player (PMP)
- General Purposes

General Description

The HE9416 is a high frequency, synchronous, rectified, step-down, switch-mode converter with internal power MOSFETs. It offers a very compact solution to achieve a 2A continuous output current over a wide input supply

range, with excellent load and line regulation. The HE9416 requires a minimal number of readily available, external components and is available in a space saving SOT23-6 package.

Typical Application

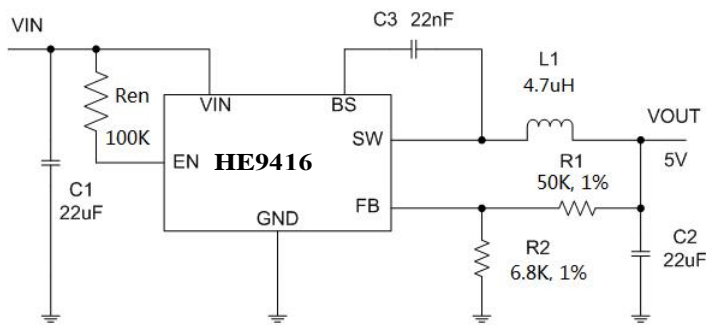

VOUT	R1	R2
5.0V	50K	6.8K
3.3V	50K	11K
1.8V	50K	25K
1.5V	50K	33.3K
1.2V	50K	50K
1.0V	50K	75K

Figure 1. Basic Application Circuit For VOUT=5V

System Block Diagram

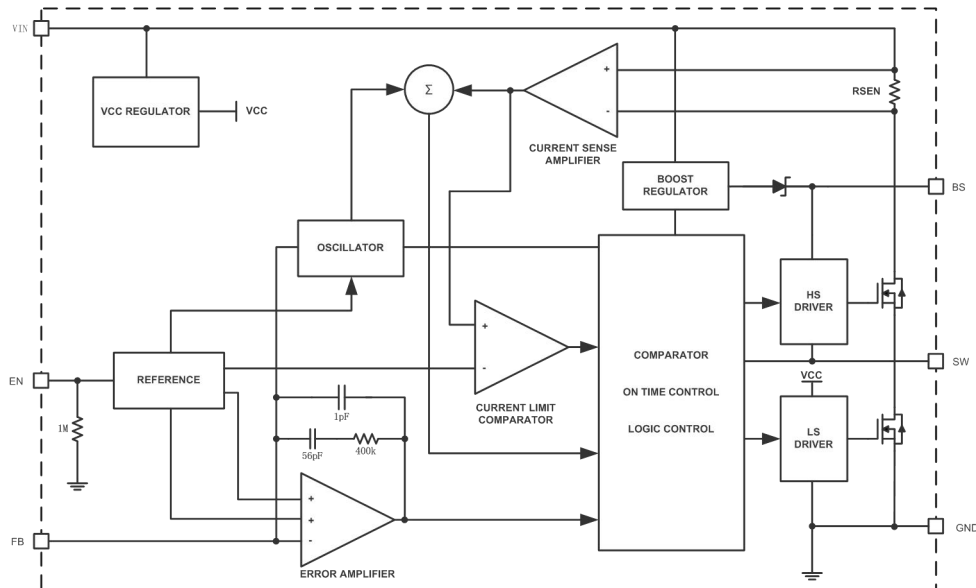

Functional Description

Internal Regulator

The HE9416 is a current mode step down DC/DC converter that provides excellent transient response with no extra external compensation components. This device contains an internal, low resistance, high voltage power

Error Amplifier

The error amplifier compares the FB pin voltage with the internal FB reference (VFB) and outputs a current proportional to the difference between the two. This output current is then used to charge or discharge the internal compensation network to form the COMP voltage,

Internal Soft-Start

The soft-start is implemented to prevent the converter output voltage from overshooting during startup. When the chip starts, the internal circuitry generates a soft-start voltage (SS) ramping up from 0V to 0.6V. When it is lower

Over Current Protection & Hiccup

The HE9416 has cycle-by-cycle over current limit when the inductor current peak value exceeds the set current limit threshold. Meanwhile, output voltage starts to drop until FB is below the Under-Voltage (UV) threshold, typically 25% below the reference. Once a UV is triggered, the HE9416 enters hiccup mode to periodically

MOSFET, and operates at a high 600K operating frequency to ensure a compact, high efficiency design with excellent AC and DC performance.

which is used to control the power MOSFET current. The optimized internal compensation network minimizes the external component counts and simplifies the control loop design.

than the internal reference (REF), SS overrides REF so the error amplifier uses SS as the reference. When SS is higher than REF, REF regains control. The SS time is internally fixed to 1.5ms.

restart the part. This protection mode is especially useful when the output is dead-short to ground. The average short circuit current is greatly reduced to alleviate the thermal issue and to protect the regulator. The HE9416 exits the hiccup mode once the over current condition is removed.

16V,2A synchronous Step-Down Converter

Startup and Shutdown

If both VIN and EN are higher than their appropriate thresholds, the chip starts. The reference block starts first, generating stable reference voltage and currents, and then the internal regulator is enabled. The regulator provides stable supply for the remaining circuitries. Three events can shut down the chip: EN low, VIN low and

thermal shutdown. In the shutdown procedure, the signaling path is first blocked to avoid any fault triggering. The COMP voltage and the internal supply rail are then pulled down. The floating driver is not subject to this shutdown command.

Pin Description

PIN	NAME	FUNCTION
1	BS	Bootstrap. A capacitor connected between SW and BST pins is required to form a floating supply across the high-side switch driver.
2	GND	GROUND Pin
3	FB	Adjustable Version Feedback input. Connect FB to the center point of the external resistor divider
4	EN	Drive this pin to a logic-high to enable the IC. Drive to a logic-low to disable the IC and enter micro-power shutdown mode.
5	IN	Power Supply Pin
6	SW	Switching Pin

Pin Configuration

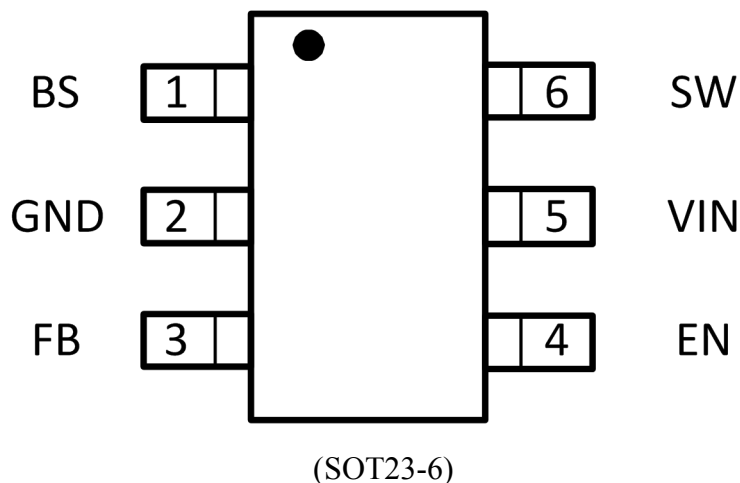

16V,2A synchronous Step-Down Converter

Absolute Maximum Ratings

Vin, EN, Voltage	-0.3V to 17V
Operating Temperature Range	-40°C to +85°C
FB Voltages	-0.3 to 6V
Lead Temperature (Soldering, 10s)	+300°C
SW Voltage	-0.3V to VIN+0.5V)
Storage Temperature Range	-65°C to 150°C
BS Voltage	(Vsw-0.3) to (Vsw+5V)

Electrical Characteristics

(VIN=12V, Vout=5V, TA = 25°C, unless otherwise noted.)

Parameter	Conditions	MIN	TYP	MAX	unit
Input Voltage Range		3.3		16	V
Supply Current in Operation	VEN=3.0V, VFB=1.1V		0.4	0.6	mA
Supply Current in Shutdown	VEN =0 or EN = GND		4		uA
Regulated Feedback Voltage	TA = 25°C, 4V ≤ VIN ≤ 18V	0.588	0.6	0.612	V
High-Side Switch On-Resistance			100		mΩ
Low-Side Switch On-Resistance			70		mΩ
High-Side Switch Leakage Current	VEN=0V, VSW=0V		0	10	uA
Upper Switch Current Limit	Minimum Duty Cycle		3		A
Oscillation Frequency			0.6		MHz
Maximum Duty Cycle	VFB=0.6V		92		%
Minimum On-Time			60		nS
Minimum Off-Time			90		nS
Thermal Shutdown			160		°C
Thermal Hysteresis			20		°C

16V,2A synchronous Step-Down Converter

Typical Performance Characteristics

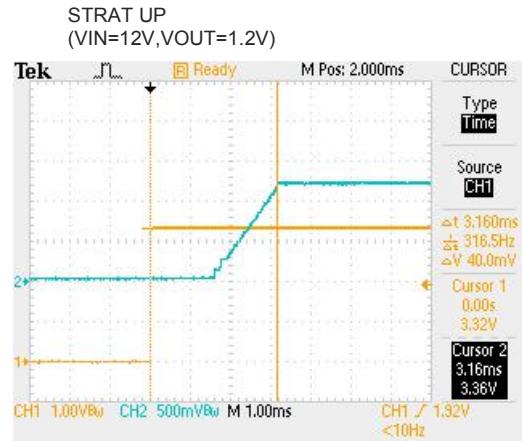
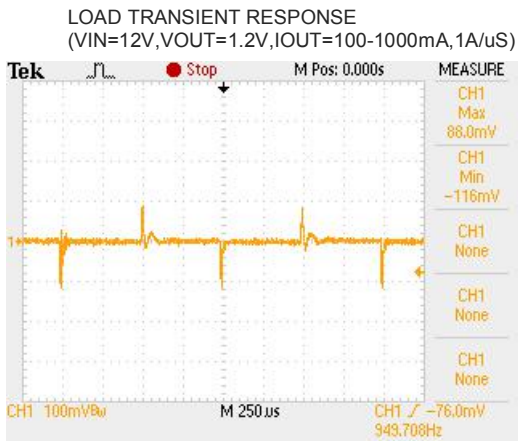
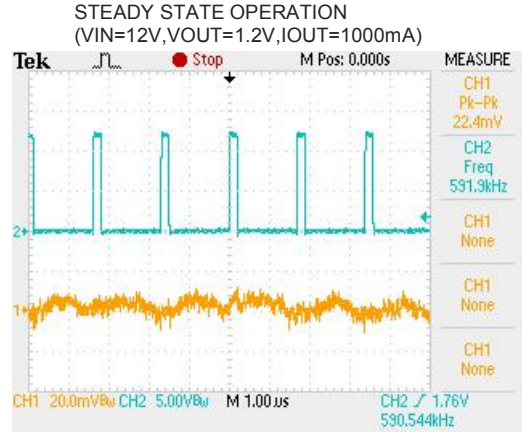
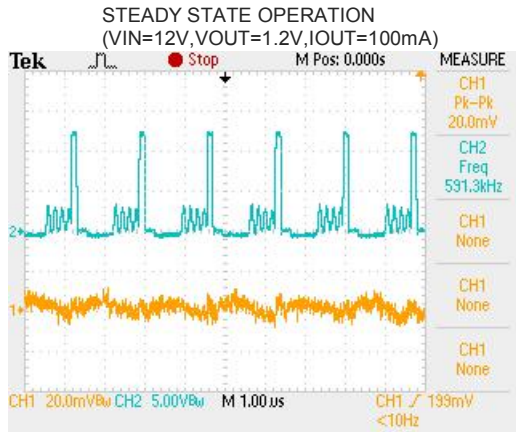
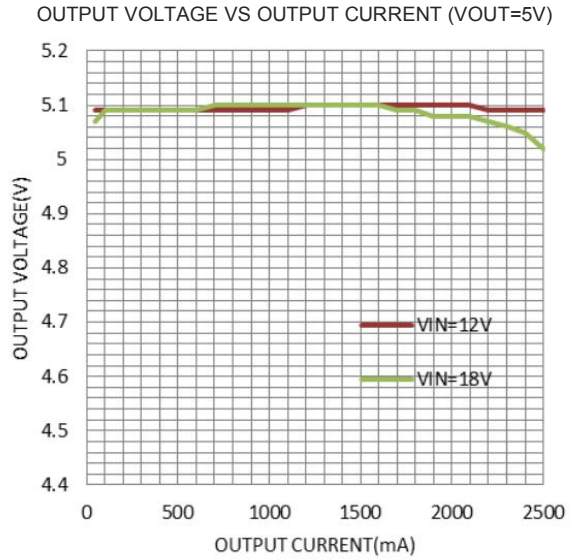
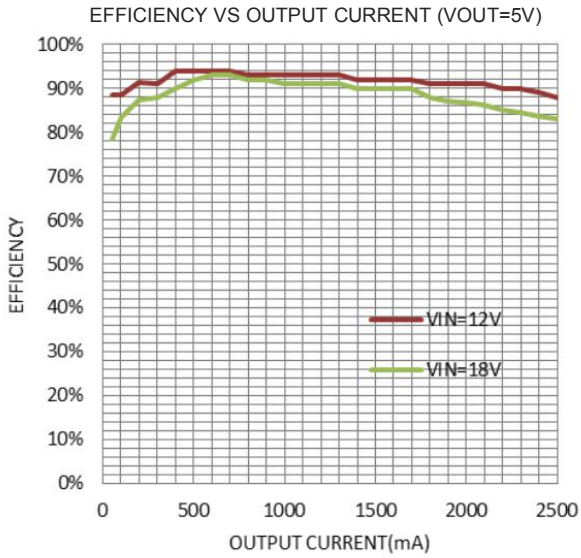

Marking Information

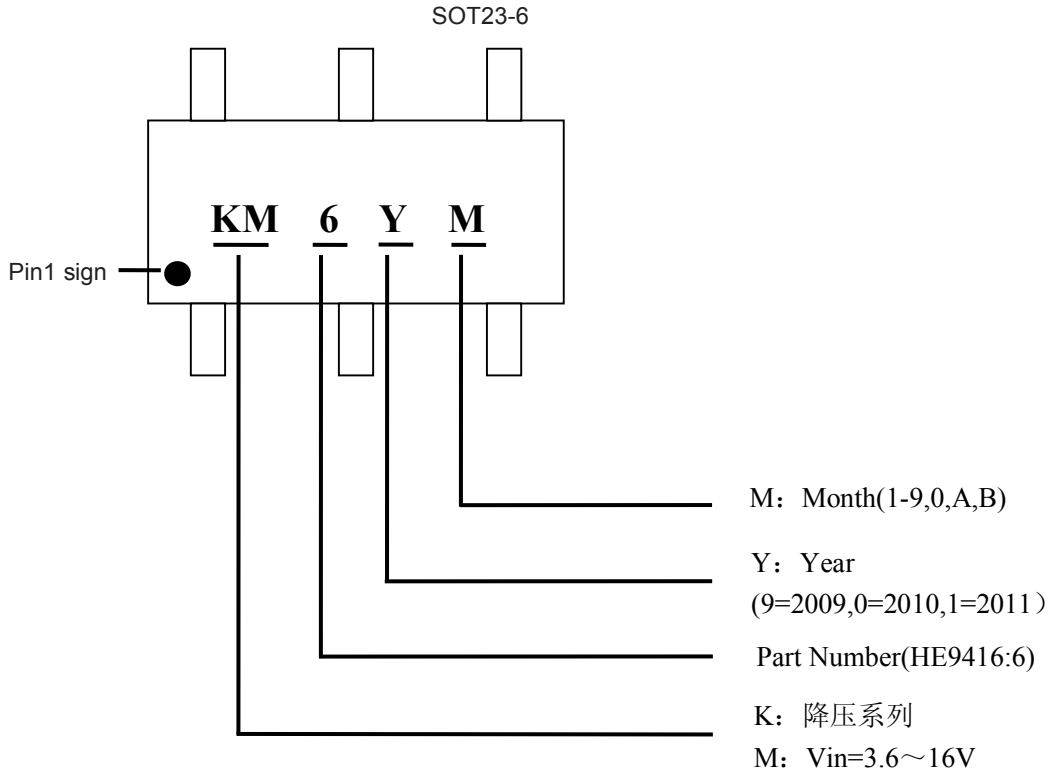

Applications Information

Setting the Output Voltage

HE9416 require an input capacitor, an output capacitor and an inductor. These components are critical to the performance of the device. HE9416 are internally compensated and do not require external components to achieve stable operation. The output voltage can be programmed by resistor divider.

$$V_{OUT} = V_{FEEDBACK} \times \frac{R1 + R2}{R2}$$

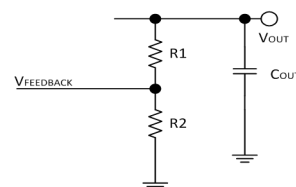

Selecting the Inductor

The recommended inductor values are shown in the Application Diagram. It is important to guarantee the inductor core does not saturate during any foreseeable operational situation. The inductor should be rated to handle the peak load current plus the ripple current: Care should be taken when reviewing the different saturation

current ratings that are specified by different manufacturers. Saturation current ratings are typically specified at 25 °C , so ratings at maximum ambient temperature of the application should be requested from the manufacturer.

$$L = \frac{V_{out} \times (V_{in} - V_{out})}{V_{in} \times \Delta I_L \times f_{OSC}}$$

$$I_{L(MAX)} = I_{LOAD} + \frac{\Delta I_L}{2}$$

Where ΔI_L is the inductor ripple current. Choose inductor ripple current to be approximately 30% of the maximum load current, 2A. The maximum inductor peak current is:

Under light load conditions below 100mA, larger inductance is recommended for improved efficiency.

Selecting the Output Capacitor

Special attention should be paid when selecting these components. The DC bias of these capacitors can result in a capacitance value that falls below the minimum value given in the recommended capacitor specifications table. The ceramic capacitor's actual capacitance can vary with temperature. The capacitor type X7R, which operates over a temperature range of -55°C to $+125^{\circ}\text{C}$, will only vary the capacitance to within $\pm 15\%$. The capacitor type X5R has a similar tolerance over a reduced temperature range of -55°C to $+85^{\circ}\text{C}$. Many large value ceramic capacitors, larger than 1uF are manufactured with Z5U or Y5V temperature characteristics. Their capacitance can drop by more than 50% as the temperature varies from 25°C to 85°C . Therefore X5R or X7R is recommended over Z5U and Y5V in applications where the ambient temperature will change significantly above or below

25°C .

Tantalum capacitors are less desirable than ceramic for use as output capacitors because they are more expensive when comparing equivalent capacitance and voltage ratings in the 0.47uF to 44uF range. Another important consideration is that tantalum capacitors have higher ESR values than equivalent size ceramics. This means that while it may be possible to find a tantalum capacitor with an ESR value within the stable range, it would have to be larger in capacitance (which means bigger and more costly) than a ceramic capacitor with the same ESR value. It should also be noted that the ESR of a typical tantalum will increase about 2:1 as the temperature goes from 25°C down to -40°C , so some guard band must be allowed.

PCB Layout Guide

PCB layout is very important to achieve stable operation. It is highly recommended to duplicate EVB layout for optimum performance. If change is necessary, please follow these guidelines and take Figure 4 for reference.

- 1) Keep the path of switching current short and minimize the loop area formed by Input capacitor, high-side MOSFET and low-side MOSFET.
- 2) Bypass ceramic capacitors are suggested to be put close to the Vin Pin.
- 3) Ensure all feedback connections are short and direct.

Place the feedback resistors and compensation components as close to the chip as possible.

- 4) VOUT, SW away from sensitive analog areas such as FB.
- 5) Connect IN, SW, and especially GND respectively to a large copper area to cool the chip to improve thermal performance and long-term reliability.
- 6) An example of 2-layer PCB layout is shown in Figure 4 for reference.

Package Description

6-pin SOT23-6 Outline Dimensions

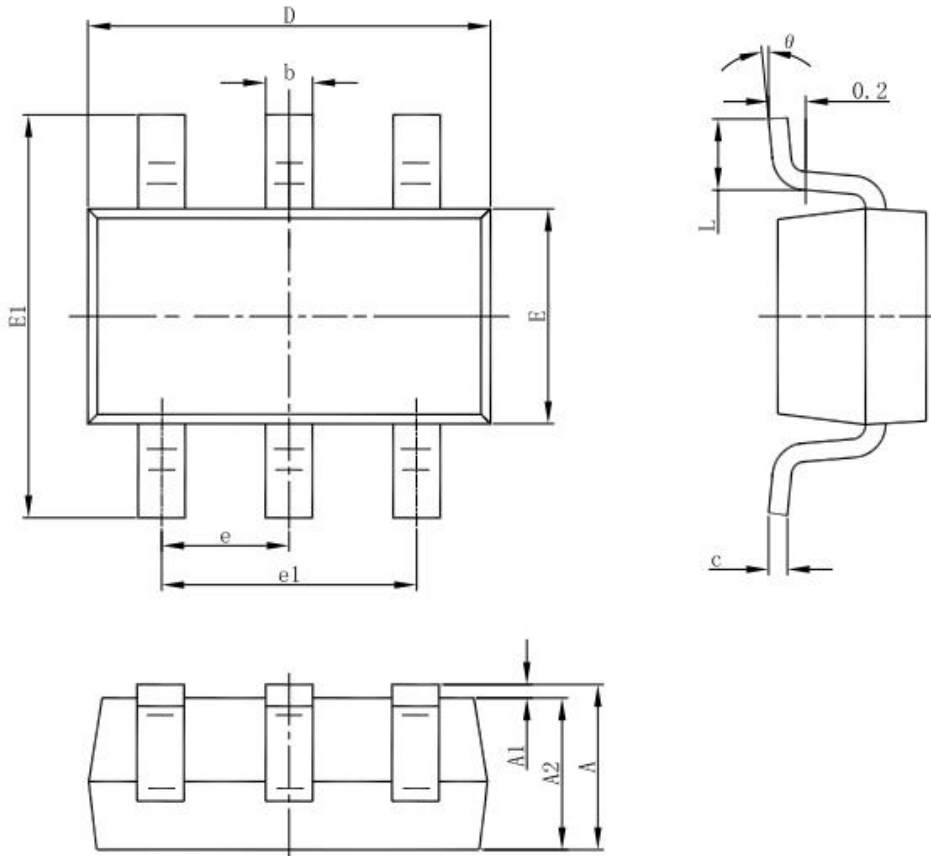

Symbol	Dimensions In Millimeters		Dimensions In Inches	
	Min	Max	Min	Max
A	1.050	1.250	0.041	0.049
A1	0.000	0.100	0.000	0.004
A2	1.050	1.150	0.041	0.045
b	0.300	0.500	0.012	0.020
c	0.100	0.200	0.004	0.008
D	2.820	3.020	0.111	0.119
E	1.500	1.700	0.059	0.067
E1	2.650	2.950	0.104	0.116
e	0.950(BSC)		0.037(BSC)	
e1	1.800	2.000	0.071	0.079
L	0.300	0.600	0.012	0.024
θ	0°	8°	0°	8°