

### Features

- Low power consumption
- Low temperature coefficient
- Built-in hysteresis characteristic
- High input voltage (up to 10V)
- Output voltage accuracy: tolerance  $\pm 1\%$  or  $\pm 2\%$
- TO92, SOT89, SOT23-3, SOT23 and SOT23-5 package

### Applications

- Battery checkers
- Level selectors
- Power failure detectors
- Microcomputer reset
- Battery memory backup
- Non-volatile RAM signal storage protectors

### General Description

The HE70XXM series devices are a set of three terminal low power voltage detectors implemented in CMOS technology. Each voltage detector in the series detects a particular fixed voltage ranging from 0.9V to 5.0V. The voltage detectors consist of a high-precision and low power consumption standard voltage source as well as a comparator,

hysteresis circuit, and an output driver (CMOS inverter or NMOS open drain). CMOS technology ensures low power consumption.

Although designed primarily as fixed voltage detectors, these devices can be used with external components to detect user specified threshold voltages.

### Selection Table

Part No.	Det. Voltage	Hys. Width	Output	Tolerance	Package
HE7009MCxx	0.9V	4%	CMOS	$\pm 1\%$ or $\pm 2\%$	TO92 SOT89 SOT23-3 SOT23 SOT23-5
HE7009MNxx	0.9V	4%	NMOS	$\pm 1\%$ or $\pm 2\%$	
HE7010MCxx	1.0V	4%	CMOS	$\pm 1\%$ or $\pm 2\%$	
HE7010MNxx	1.0V	4%	NMOS	$\pm 1\%$ or $\pm 2\%$	
HE7011MCxx	1.1V	4%	CMOS	$\pm 1\%$ or $\pm 2\%$	
HE7011MNxx	1.1V	4%	NMOS	$\pm 1\%$ or $\pm 2\%$	
HE7012MCxx	1.2V	4%	CMOS	$\pm 1\%$ or $\pm 2\%$	
HE7012MNxx	1.2V	4%	NMOS	$\pm 1\%$ or $\pm 2\%$	
...	...	4%	...	$\pm 1\%$ or $\pm 2\%$	
HE7050MCxx	5.0V	4%	CMOS	$\pm 1\%$ or $\pm 2\%$	
HE7050MNxx	5.0V	4%	NMOS	$\pm 1\%$ or $\pm 2\%$	

### Order Information

HE70①②③④⑤⑥⑦

Designator	Symbol	Description
① ②	Integer	Output Voltage(0.9~5.0V)
③	M	Standard
④	C	CMOS output
	N	NMOS output
⑤	T	Package:TO-92
	P	Package:SOT89
	M	Package:SOT23-3
	N	Package:SOT23
	M5	Package:SOT23-5
⑥	R	RoHS / Pb Free
	G	Halogen Free
⑦	1	±1% accuracy

Note: if ⑦ is omitted, the accuracy is ±2% accuracy

### Block Diagram

(1) CMOS Output

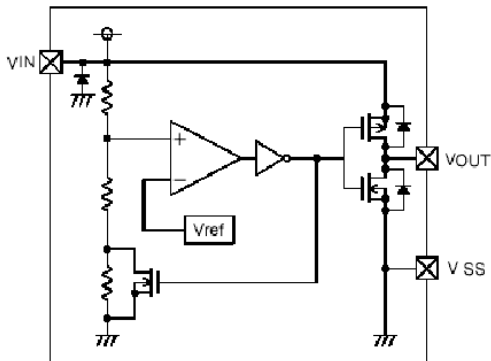

(2) N-ch Open Drain Output

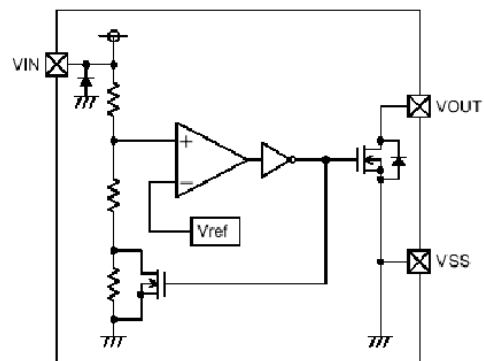

**Output Table & Curve**

$V_{DD}$	$V_{DD} > V_{DET}(+)$	$V_{DD} \leq V_{DET}(-)$
$V_{OUT}$	Hi-Z	$V_{SS}$

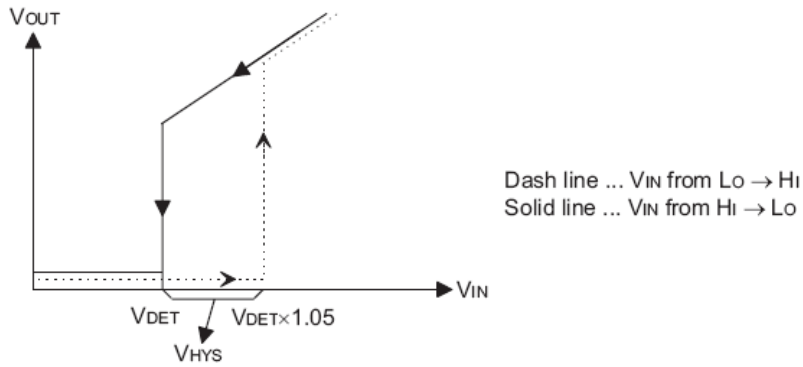

**Pin Assignment**

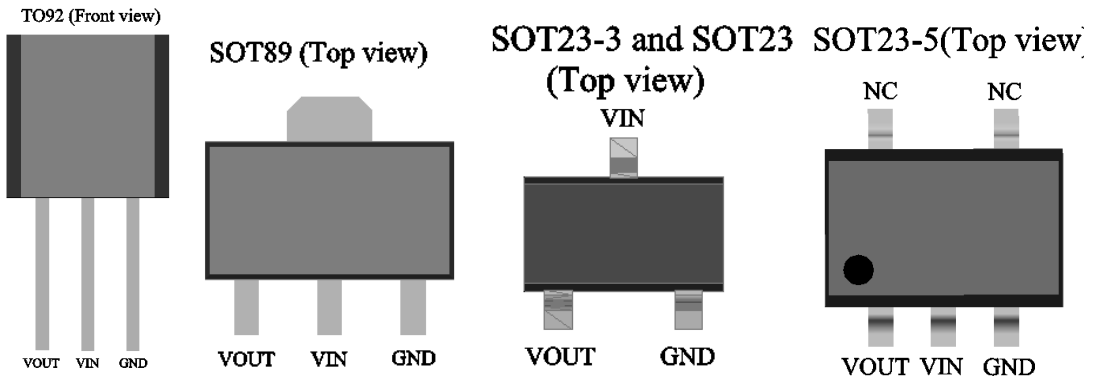

### Marking Rule

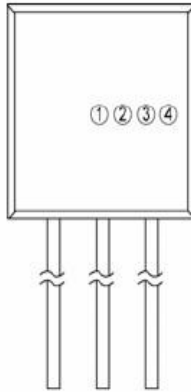

TO-92  
(TOP VIEW)

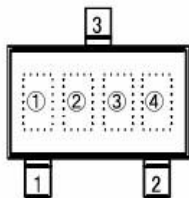

SOT23-3  
(TOP VIEW)

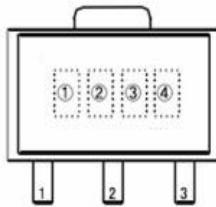

SOT-89  
(TOP VIEW)

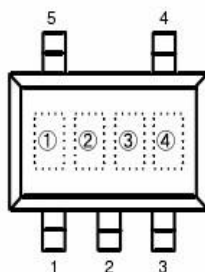

SOT23-5  
(TOP VIEW)

① Represents integer of detect voltage and CMOS Output

MARK	CONFIGURATION	VOLTAGE (V)
A	CMOS	0.X
B	CMOS	1.X
C	CMOS	2.X
D	CMOS	3.X
E	CMOS	4.X
F	CMOS	5.X
H	CMOS	6.X

N-Channel Open Drain Output

MARK	CONFIGURATION	VOLTAGE (V)
K	N-ch	0.X
L	N-ch	1.X
M	N-ch	2.X
N	N-ch	3.X
P	N-ch	4.X
R	N-ch	5.X
S	N-ch	6.X

② Represents decimal number of detect voltage

MARK	VOLTAGE (V)	MARK	VOLTAGE (V)
0	X.0	5	X.5
1	X.1	6	X.6
2	X.2	7	X.7
3	X.3	8	X.8
4	X.4	9	X.9

③ Represents accuracy

MARK	ACCURACY
3	2%
1	1%

④ Represents production lot number

Based on the internal standard. (G, I, J, O, Q, W excepted)

#### Absolute Maximum Ratings

Supply Voltage .....-0.3V to 11V      Storage Temperature .....-50°C to 125°C  
 Operating Temperature .....-40°C to 85°C

Note: These are stress ratings only. Stresses exceeding the range specified under “Absolute Maximum Ratings” may cause substantial damage to the device. Functional operation of this device at other conditions beyond those listed in the specification is not implied and prolonged exposure to extreme conditions may affect device reliability.

#### Thermal Information

Symbol	Parameter	Package	Max.	Unit
$\theta_{JA}$	Thermal Resistance (Junction to Ambient) (Assume no ambient airflow, no heat sink)	SOT23	500	°C/W
		SOT89	200	°C/W
		TO92	200	°C/W
$P_D$	Power Dissipation	SOT23	0.20	W
		SOT89	0.50	W
		TO92	0.50	W

Note:  $P_D$  is measured at  $T_a = 25^\circ\text{C}$

#### Electrical Characteristics

$V_{DF} = 0.8\text{V} \sim 5.0\text{V}$

$T_a = 25^\circ\text{C}$

Symbol	Parameter	Test Conditions		Min.	Typ.	Max.	Unit
$V_{DET}$	Detection Voltage	$V_{DF} = 0.8\text{V} \sim 2.2\text{V}$ $V_{DF} = 2.3\text{V} \sim 5.0\text{V}$		$V_{DF} * 0.98$	$V_{DF}$	$V_{DF} * 1.02$	V
$V_{HYS}$	Hysteresis Width	-		$0.02 * V_{DET}$	$0.04 * V_{DET}$	$0.08 * V_{DET}$	V
$I_{DD}$	Operating Current	$V_{in} = 1.5\text{V}$		-	0.7	2.3	$\mu\text{A}$
		$V_{in} = 2.0\text{V}$		-	0.8	2.7	
		$V_{in} = 3.0\text{V}$		-	0.9	3.0	
		$V_{in} = 4.0\text{V}$		-	1.0	3.2	
		$V_{in} = 5.0\text{V}$		-	1.1	3.6	
$V_{DD}$	Operating Voltage	-	-	0.7	-	10	V
$I_{OL}$	Output Sink Current	2V	$V_{OUT} = 0.2\text{V}$	0.5	1	-	mA
$\frac{\Delta V_{DET}}{V_{DF} \Delta T_a}$	Temperature Coefficient	-	-25°C < $T_a$ <125°C	-	$\pm 100$	-	ppm/°C

### Typical Performance Characteristics

#### (1) Output Voltage vs Input voltage

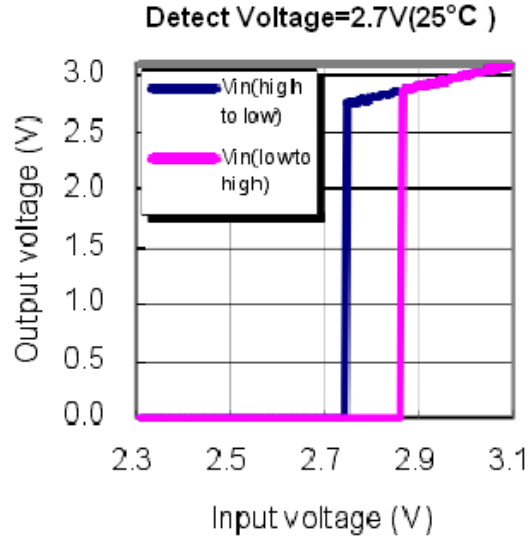
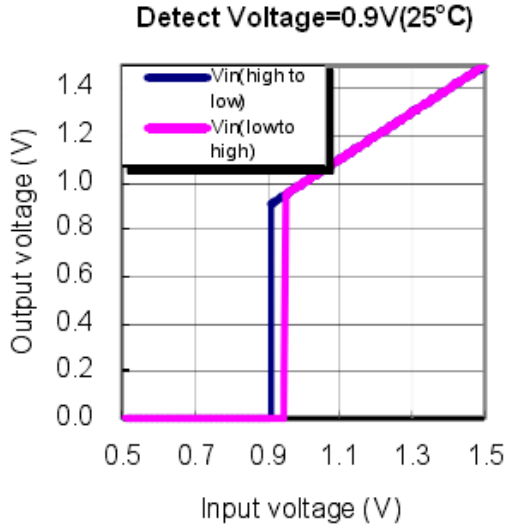

#### (2) Supply Current vs. Input Voltage

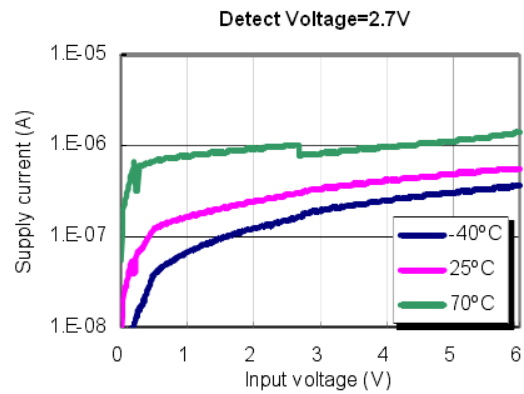
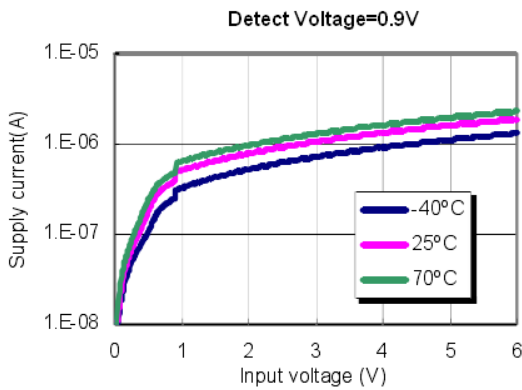

#### (3) Detect, Release Voltage vs. Ambient Temperature

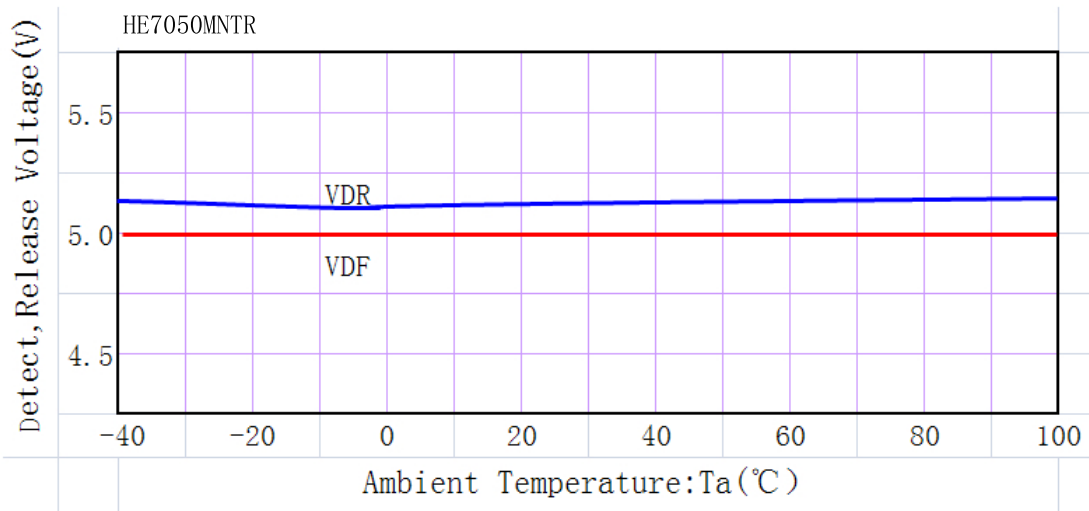

### Application Circuits

#### Microcomputer Reset Circuit

Normally a reset circuit is required to protect the microcomputer system from malfunctions due to power line interruptions. The following examples show how different output configurations perform a reset function in various systems.

NMOS open drain output application for separate power supply

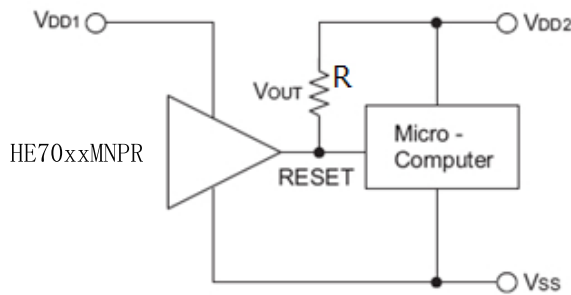

$R=47K$

NMOS open drain output application with R-C delay

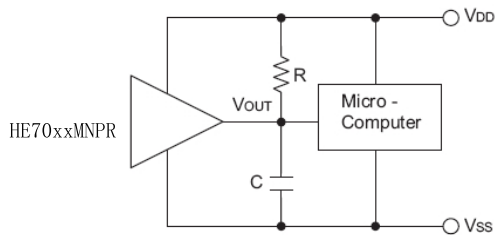

#### Power-on Reset Circuit

With several external components, the NMOS open drain type of the HE70XXM series can be used to perform a power-on reset function as shown:

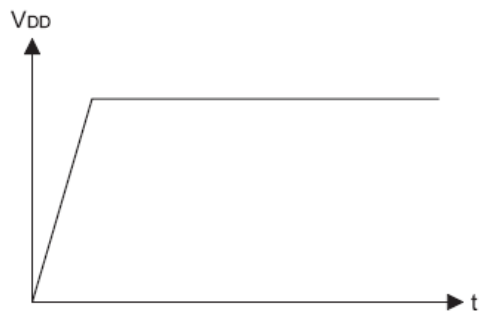
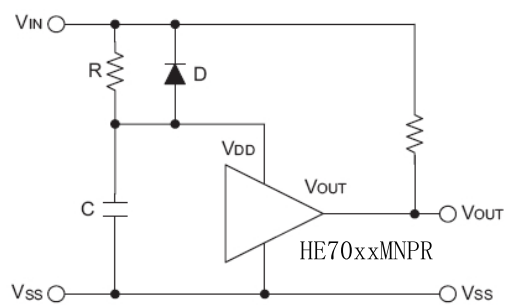

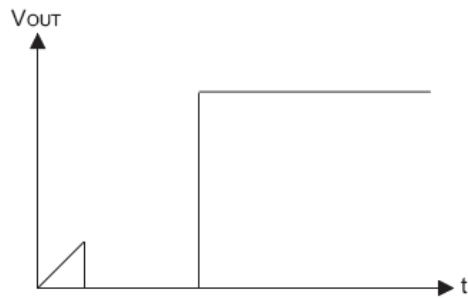

### 5V Power Line Monitoring Circuit

Generally, a minimum operating voltage of 4.5V is guaranteed in a 5V power line system.

5V power line monitor with power-on reset

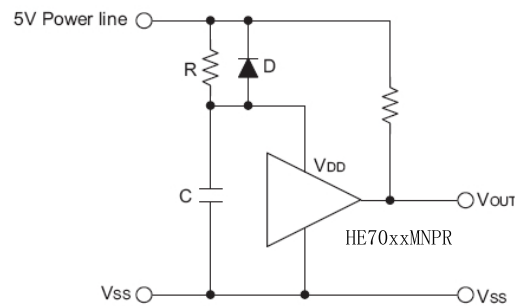

With 5V voltage regulator

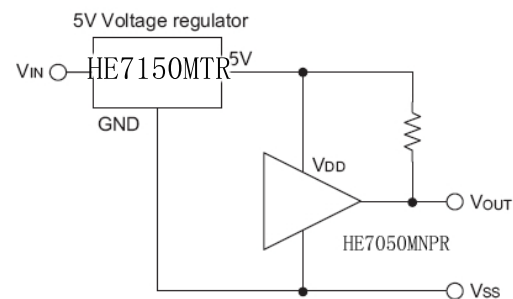

### Change of Detectable Voltage

If the required voltage is not found in the standard product selection table, it is possible to change it by using external resistance dividers or diodes.

Varying the detectable voltage with a resistance divider

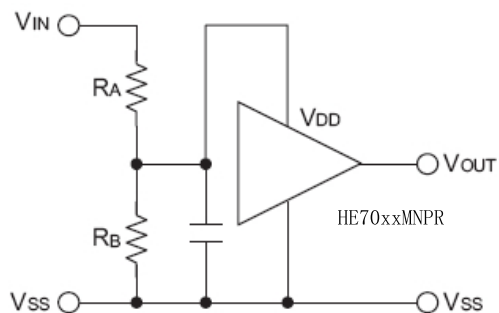



$$\text{Detectable voltage} = \frac{R_A + R_B}{R_B} \times V_{DET}$$

$$\text{Hysteresis width} = \frac{R_A + R_B}{R_B} \times V_{HYS}$$

Varying the detectable voltage with a diode

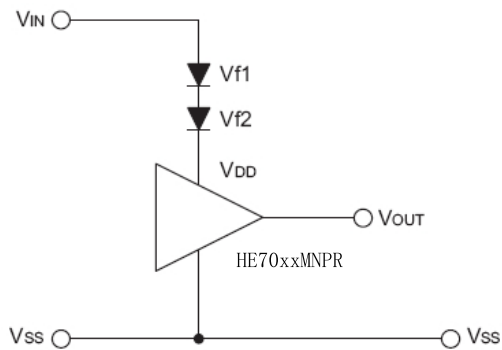

$$\text{Detectable Voltage} = V_{f1} + V_{f2} + V_{DET}$$

### Malfunction Analysis

The following circuit demonstrates the way a circuit analyzes malfunctions by monitoring the variation or spike noise of power supply voltage.

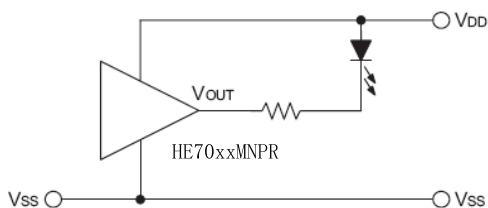

### Charge Monitoring Circuit

The following circuit shows a charged monitor for protection against battery deterioration by overcharging. When the voltage of the battery is higher than the set detectable voltage, the transistor turns onto bypass the charge current, protecting the battery from overcharging.

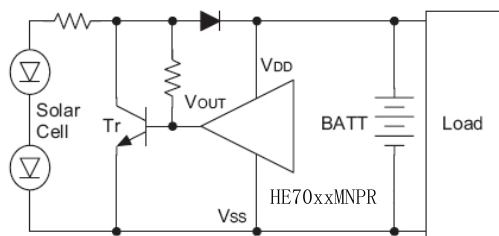

### Level Selector

The following diagram illustrates a logic level selector.

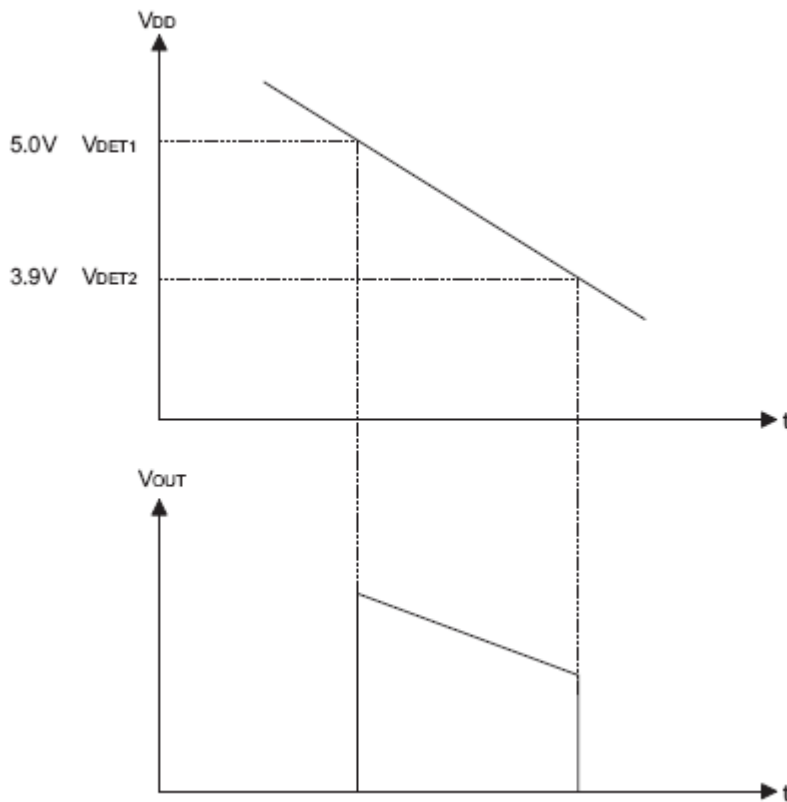
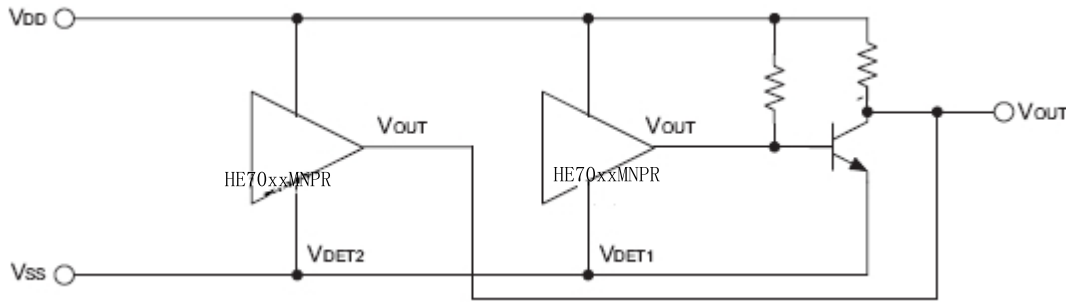

**Package Information**  
**3-pin TO92 Outline Dimensions**

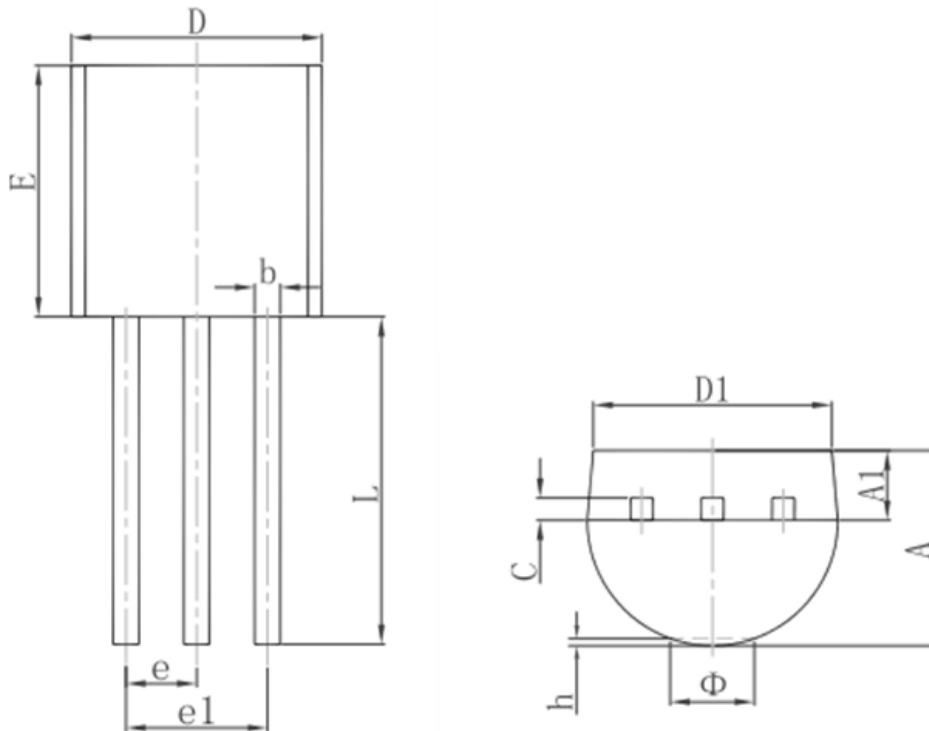

Symbol	Dimensions In Millimeters		Dimensions In Inches	
	Min.	Max.	Min.	Max.
A	3.300	3.700	0.130	0.146
A1	1.100	1.400	0.043	0.055
b	0.380	0.550	0.015	0.022
c	0.360	0.510	0.014	0.020
D	4.300	4.700	0.169	0.185
D1	3.430		0.135	
E	4.300	4.700	0.169	0.185
e	1.270 TYP.		0.050 TYP.	
e1	2.440	2.640	0.096	0.104
L	14.100	14.500	0.555	0.571
Φ		1.600		0.063
h	0.000	0.380	0.000	0.015

**3-pin SOT89 Outline Dimensions**

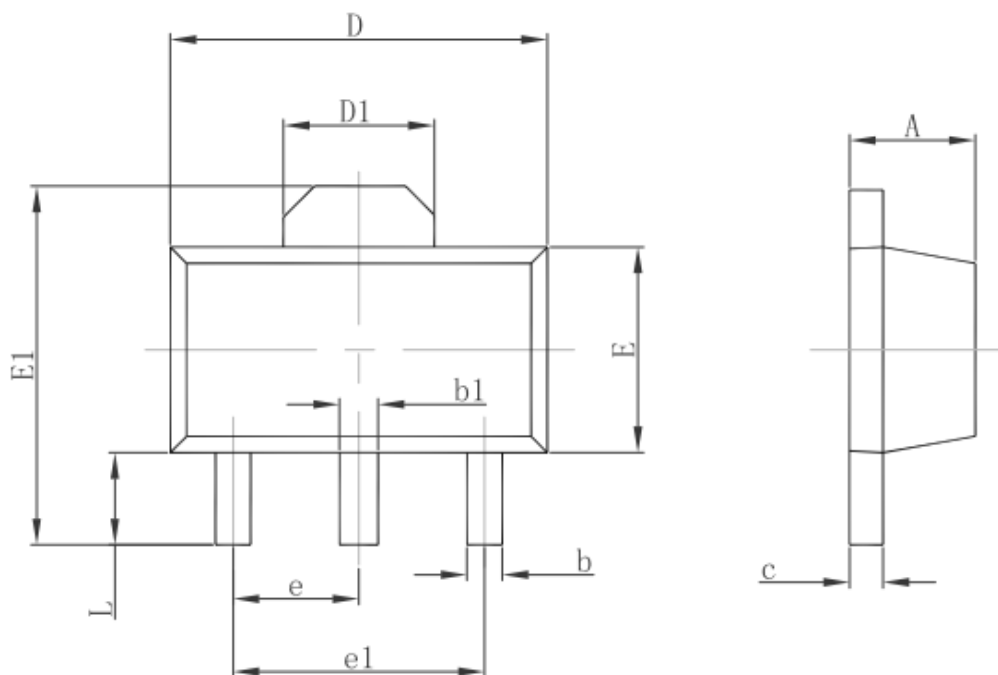

Symbol	Dimensions In Millimeters		Dimensions In Inches	
	Min.	Max.	Min.	Max.
A	1.400	1.600	0.055	0.063
b	0.320	0.520	0.013	0.020
b1	0.400	0.580	0.016	0.023
c	0.350	0.440	0.014	0.017
D	4.400	4.600	0.173	0.181
D1	1.550 REF.		0.061 REF.	
E	2.300	2.600	0.091	0.102
E1	3.940	4.250	0.155	0.167
e	1.500 TYP.		0.060 TYP.	
e1	3.000 TYP.		0.118 TYP.	
L	0.900	1.200	0.035	0.047

### 3-pin SOT23-3 Outline Dimensions

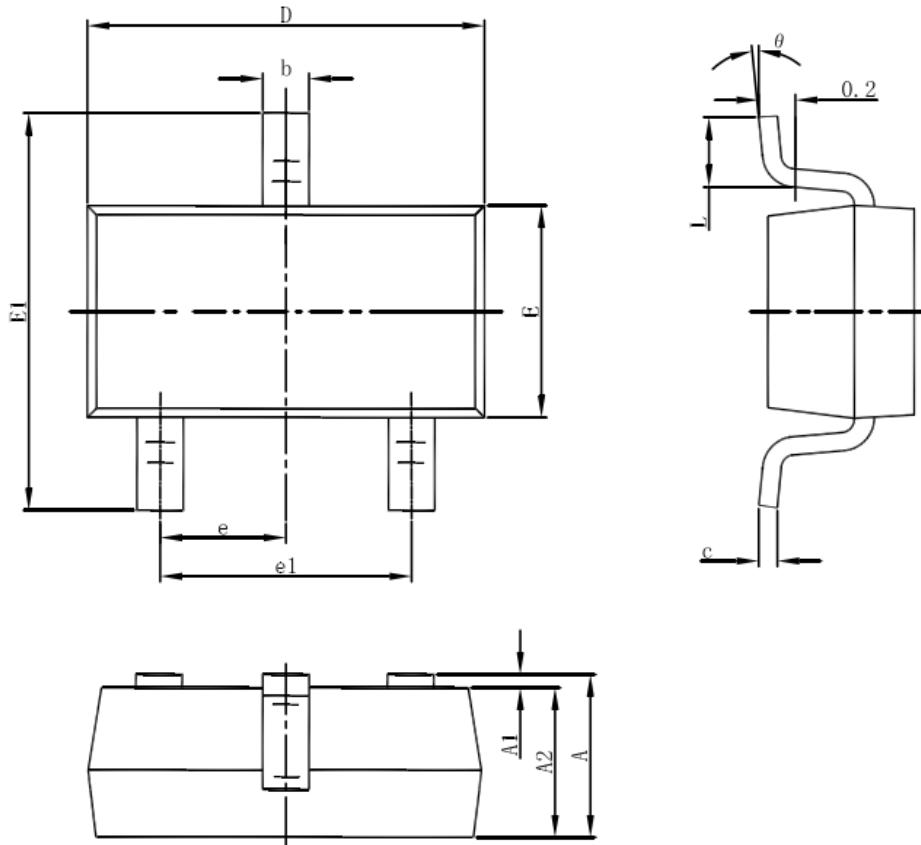

Symbol	Dimensions In Millimeters		Dimensions In Inches	
	Min	Max	Min	Max
A	1.050	1.250	0.041	0.049
A1	0.000	0.100	0.000	0.004
A2	1.050	1.150	0.041	0.045
b	0.300	0.500	0.012	0.020
c	0.100	0.200	0.004	0.008
D	2.820	3.020	0.111	0.119
E	1.500	1.700	0.059	0.067
E1	2.650	2.950	0.104	0.116
e	0.950(BSC)		0.037(BSC)	
e1	1.800	2.000	0.071	0.079
L	0.300	0.600	0.012	0.024
θ	0°	8°	0°	8°

**3-pin SOT23 Outline Dimensions**

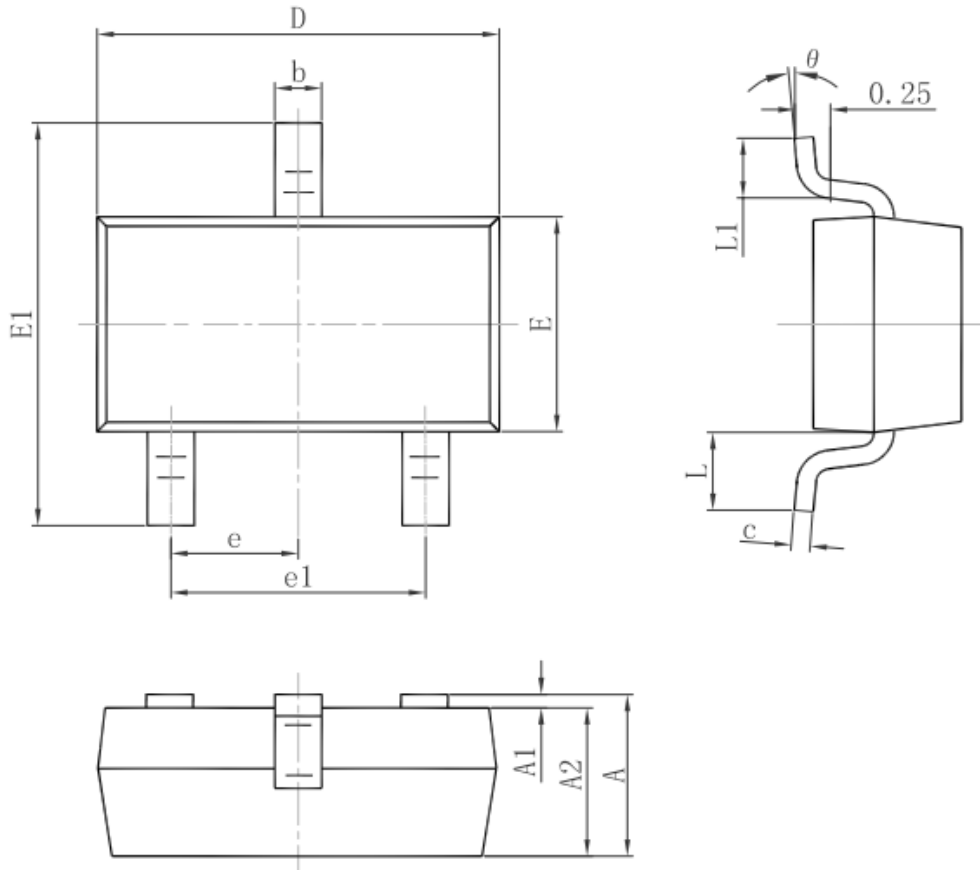

Symbol	Dimensions In Millimeters		Dimensions In Inches	
	Min.	Max.	Min.	Max.
A	0.900	1.150	0.035	0.045
A1	0.000	0.100	0.000	0.004
A2	0.900	1.050	0.035	0.041
b	0.300	0.500	0.012	0.020
c	0.080	0.150	0.003	0.006
D	2.800	3.000	0.110	0.118
E	1.200	1.400	0.047	0.055
E1	2.250	2.550	0.089	0.100
e	0.950 TYP.		0.037 TYP.	
e1	1.800	2.000	0.071	0.079
L	0.550 REF.		0.022 REF.	
L1	0.300	0.500	0.012	0.020
θ	0°	8°	0°	8°

**5-pin SOT23-5 Outline Dimensions**

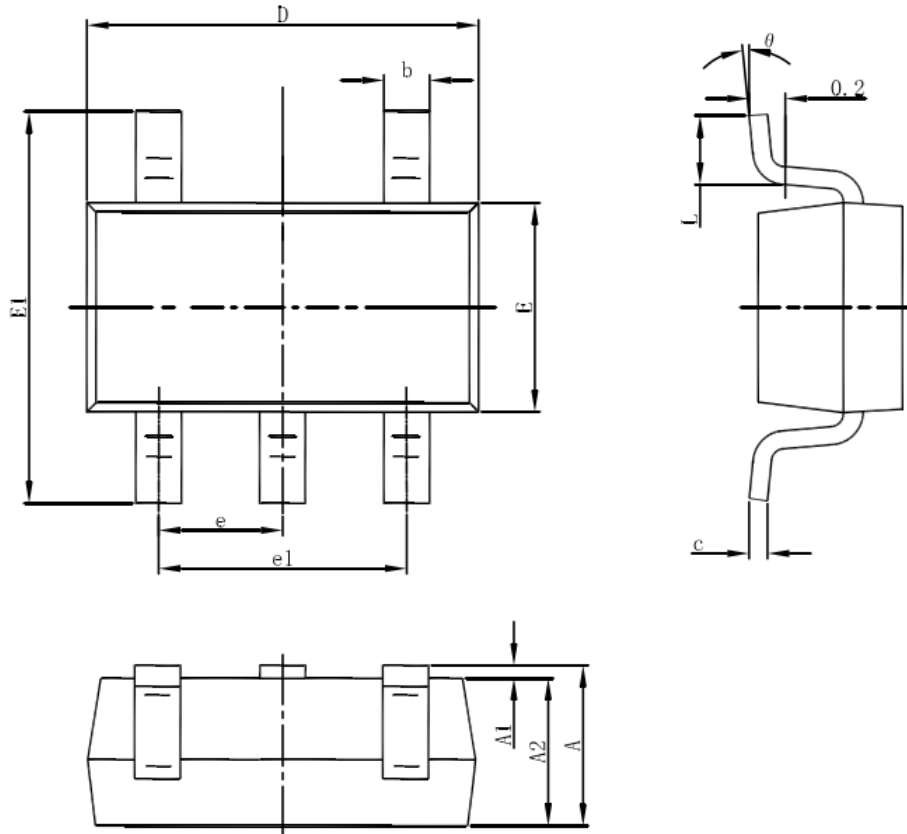

Symbol	Dimensions In Millimeters		Dimensions In Inches	
	Min	Max	Min	Max
A	1.050	1.250	0.041	0.049
A1	0.000	0.100	0.000	0.004
A2	1.050	1.150	0.041	0.045
b	0.300	0.500	0.012	0.020
c	0.100	0.200	0.004	0.008
D	2.820	3.020	0.111	0.119
E	1.500	1.700	0.059	0.067
E1	2.650	2.950	0.104	0.116
e	0.950(BSC)		0.037(BSC)	
e1	1.800	2.000	0.071	0.079
L	0.300	0.600	0.012	0.024
θ	0°	8°	0°	8°