

General Description

The HE9009M6R is a high performance charge pump DC/DC converter that produces a regulated 5V output. No external inductor is required for operation. The operating voltage range is 2.8V to V_{OUT} . Internal soft-start circuitry effectively reduces the in-rush current both while start-up and mode change.

The HE9009M6R features very low quiescent current, over current protection and short circuit protection.

The HE9009M6R is available in SOT23-6 package.

Features

- ◆ 2x Mode for Ultra-High Efficiency
- ◆ 2.8V to V_{OUT} Range Input Voltage
- ◆ Soft Start Function
- ◆ Built-In Short-Circuit Protection
- ◆ 340KHz Fixed frequency
- ◆ Built-in Thermal Protection
- ◆ Over Current Protection Function
- ◆ $I_{SD} < 1\mu A$ in Shutdown
- ◆ SOT23-6 Package
- ◆ RoHS Compliant and 100% Lead (Pb)-Free

Order Information

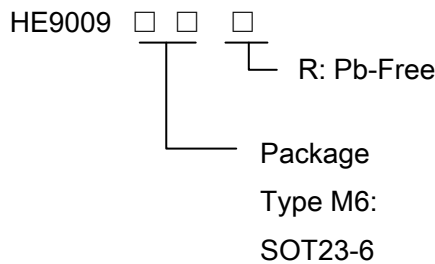

Typical Application Circuit

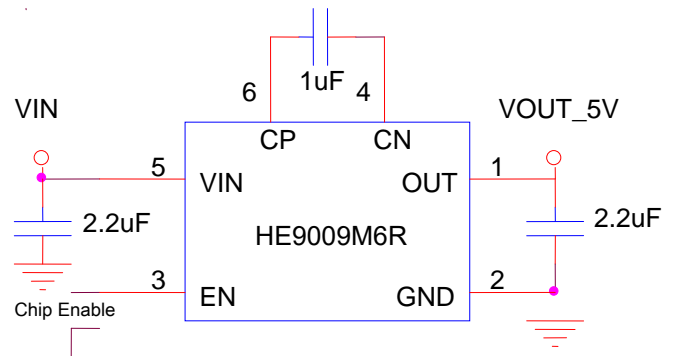

Marking Information

Device	Marking	Package	Shipping
HE9009M6R	10A45	SOT23-6	3K/REEL
Marking indication: Y:Production year W:Production week X: Series Number			

Applications

- ◇ LCD Panel
- ◇ Cellular and Smart mobile phone
- ◇ PDA/DSC
- ◇ Flash LED Driver

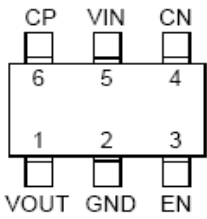
Package Type		Pin Configurations
SOT23-6		(TOP VIEW) 
Pin	Name	Description
1	VOUT	Output Voltage.
2	GND	Ground.
3	EN	Chip Enable (Active High).
4	CN	Flying Capacitor Negative Terminal.
5	VIN	Power Input Voltage.
6	CP	Flying Capacitor Positive Terminal.

Function Block Diagram

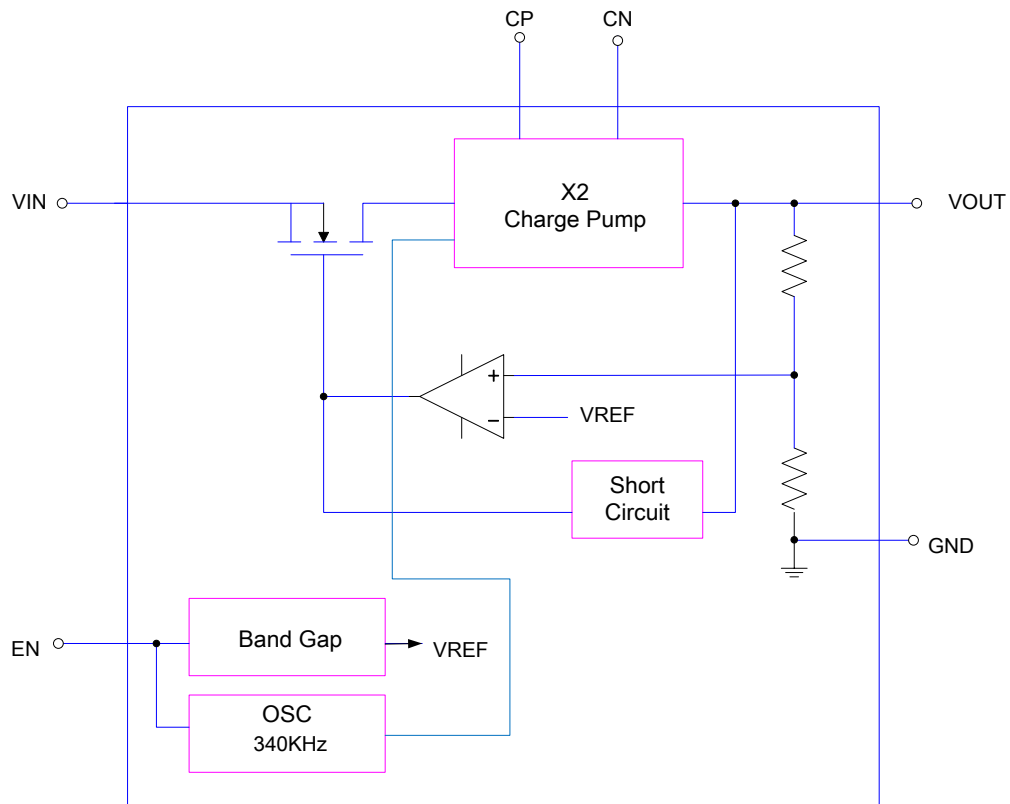

Absolute Maximum Ratings ^{Note 1}

- ✧ Input Voltage to GND (V_{IN}) ----- 6V
- ✧ EN to GND Voltage (V_{EN}) ----- 0.3V to $V_{IN}+0.3V$
- ✧ Operating Junction Temperature Range ----- 125°C
- ✧ Maximum Soldering Temperature (at leads, 10sec) ----- 260°C

Note 1. Stresses beyond those listed under “Absolute Maximum Ratings” may cause permanent damage to the device. These are stress ratings only, and functional operation of the device at these or any other conditions beyond those indicated in the operational sections of the specifications is not implied. Exposure to absolute maximum rating conditions for extended periods may affect device reliability.

Thermal Information

- ✧ Maximum Power Dissipation (P_D) ----- 0.45W
- ✧ Thermal Resistance (J_A) ----- 250°C/W

ESD Susceptibility

- ✧ HBM(Human Body Mode) ----- 2KV
- ✧ MM(Machine Mode) ----- 200V

Recommended Operating Conditions

- ✧ Operation Ambient Temperature Range ----- - 20°C to 85°C

Electrical Characteristics

(Over recommended operating conditions unless specified otherwise, $V_{IN}=3.6V, EN=High, TA=25^\circ C$)

Parameter	Symbol	Condition	Min	Typ	Max	Units
Input Voltage	V_{IN}		2.8		V_{OUT}	V
Output Voltage Range	V_{OUT}			5		V
Quiescent Current	I_Q	No Load		2		mA
Shutdown Current	I_{SHDN}	$V_{EN} = GND$			1	μA
Oscillator Frequency	f_{OSC}			340		KHz
Output Short Circuit Current Limit	I_{SC}	$V_{OUT} < 0.5V$	300	350		mA
Enable Threshold Low	$V_{EN(L)}$				0.4	V
Enable Threshold High	$V_{EN(H)}$		1.4			V
Enable Current	I_{EN}	$V_{IN} = V_{EN} = 5V$		1		μA

Application Information

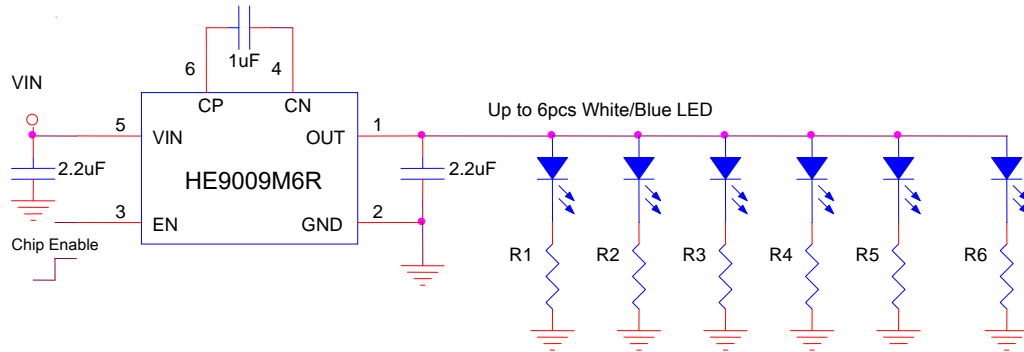

Figure1: Up to 6pcs White/Blue LED Driver from Li-Ion Battery Source

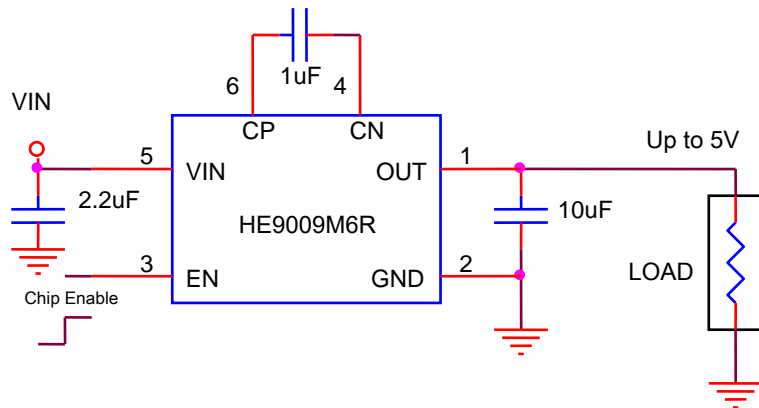
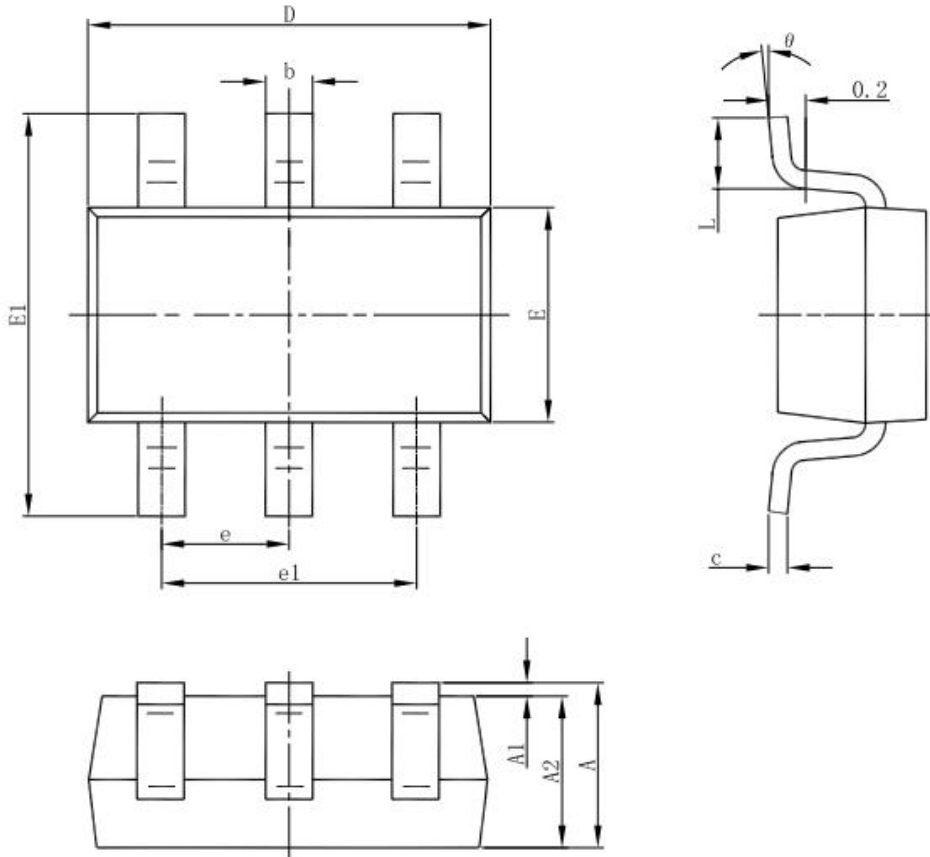

Figure2: Step-up to 5V with loading application from Li-Ion Battery Source

Package Description
6-pin SOT23-6 Outline Dimensions

Symbol	Dimensions In Millimeters		Dimensions In Inches	
	Min	Max	Min	Max
A	1.050	1.250	0.041	0.049
A1	0.000	0.100	0.000	0.004
A2	1.050	1.150	0.041	0.045
b	0.300	0.500	0.012	0.020
c	0.100	0.200	0.004	0.008
D	2.820	3.020	0.111	0.119
E	1.500	1.700	0.059	0.067
E1	2.650	2.950	0.104	0.116
e	0.950(BSC)		0.037(BSC)	
e1	1.800	2.000	0.071	0.079
L	0.300	0.600	0.012	0.024
θ	0°	8°	0°	8°