

### Features

- Low power consumption
- Low voltage drop
- Low temperature coefficient
- Ultra low quiescent current: 2 $\mu$ A(typ.)
- High input voltage (up to 24V)
- Maximum output current: 300mA
- Output voltage accuracy: tolerance  $\pm$ 2%
- TO92, SOT89, SOT23-3 and SOT23 package

### Applications

- Battery-powered equipment
- Communication equipment
- Audio/Video equipment

### General Description

The HE73XXS series is a set of three-terminal low power high voltage regulators implemented in CMOS technology. They allow input voltages as high as 24V. The series features extremely low quiescent current which is typically 2 $\mu$ A. They are available with several fixed output voltages ranging from 2.5V to 5.0V. CMOS technology ensures low voltage drop and low quiescent current. Although designed primarily as fixed voltage regulators, these devices can be used with external components to obtain variable voltages and currents.

### Selection Table

Part No.	Output Voltage	Package	Marking
HE7325Sxx	2.5V	TO92 SOT89 SOT23-3 SOT23	73XX-A(for TO92) 73XX-A(for SOT89) 3XX(for SOT23-3) 3XX(for SOT23)
HE7328Sxx	2.8V		
HE7330Sxx	3.0V		
HE7333Sxx	3.3V		
HE7336Sxx	3.6V		
HE7340Sxx	4.0V		
HE7344Sxx	4.4V		
HE7350Sxx	5.0V		

### Order Information

HE73①②③④⑤

Designator	Symbol	Description
① ②	Integer	Output Voltage(2.5~5.0V)
③	S	Standard
④	T	Package:TO-92
	P	Package:SOT89-3
	M	Package:SOT23-3
	N	Package:SOT23
⑤	R	RoHS / Pb Free
	G	Halogen Free

### Block Diagram

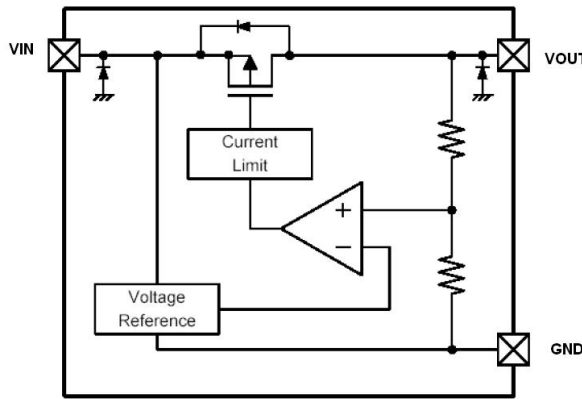

\*Diodes inside the circuit are an ESD protection diode and a parasitic diode.

### Pin Assignment

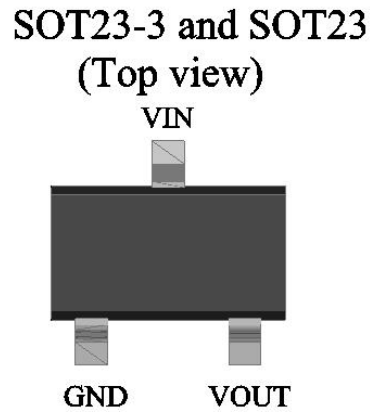
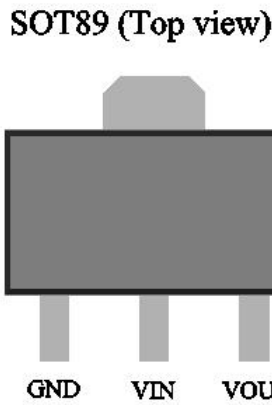
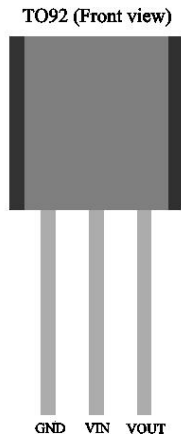

### Absolute Maximum Ratings

Supply Voltage .....-0.3V to 24V      Storage Temperature .....-50°C to 125°C  
 Operating Temperature .....-30°C to 85°C

Note: These are stress ratings only. Stresses exceeding the range specified under “Absolute Maximum Ratings” may cause substantial damage to the device. Functional operation of this device at other conditions beyond those listed in the specification is not implied and prolonged exposure to extreme conditions may affect device reliability.

### Thermal Information

Symbol	Parameter	Package	Max.	Unit
$\theta_{JA}$	Thermal Resistance (Junction to Ambient) (Assume no ambient airflow, no heat sink)	SOT23	500	°C/W
		SOT89	200	°C/W
		TO92	200	°C/W
$P_D$	Power Dissipation	SOT23	0.20	W
		SOT89	0.50	W
		TO92	0.50	W

Note:  $P_D$  is measured at  $T_a = 25^\circ\text{C}$

### Electrical Characteristics

#### HE7325Sxx, +2.5V Output Type

Symbol	Parameter	Test Conditions		Min.	Typ.	Max.	Unit
		V <sub>IN</sub>	Conditions				
V <sub>OUT</sub>	Output Voltage	4.5V	I <sub>OUT</sub> =40mA	2.45	2.500	2.55	V
I <sub>OUT</sub>	Output Current	4.5V	-	-	300	-	mA
ΔV <sub>OUT</sub>	Load Regulation	4.5V	1mA ≤ I <sub>OUT</sub> ≤ 60mA	-	45	90	mV
V <sub>DIF</sub>	Voltage Drop(Note)	-	I <sub>OUT</sub> =40mA, ΔV <sub>OUT</sub> =2%	-	100	-	mV
I <sub>SS</sub>	Current Consumption	4.5V	No load	-	2.0	3.0	μA
$\frac{\Delta V_{OUT}}{\Delta V_{IN} \times V_{OUT}}$	Line Regulation	-	3.5V ≤ V <sub>IN</sub> ≤ 12V I <sub>OUT</sub> =40mA	-	0.2	-	%/V
V <sub>IN</sub>	Input Voltage	-	-	-	-	24	V
$\frac{\Delta V_{OUT}}{\Delta T_a}$	Temperature Coefficient	4.5V	I <sub>OUT</sub> =40mA -40°C < T <sub>a</sub> < 85°C	-	±0.5	-	mV/°C

Note: Dropout voltage is defined as the input voltage minus the output voltage that produces a 2% change in the output voltage from the value at V<sub>IN</sub> = V<sub>OUT</sub>+1V with a fixed load.

#### HE7328Sxx, +2.8V Output Type

Symbol	Parameter	Test Conditions		Min.	Typ.	Max.	Unit
		V <sub>IN</sub>	Conditions				
V <sub>OUT</sub>	Output Voltage	4.8V	I <sub>OUT</sub> =10mA	2.744	2.800	2.856	V
I <sub>OUT</sub>	Output Current	4.8V	-	-	300	-	mA
ΔV <sub>OUT</sub>	Load Regulation	4.8V	1mA ≤ I <sub>OUT</sub> ≤ 60mA	-	45	90	mV
V <sub>DIF</sub>	Voltage Drop(Note)	-	I <sub>OUT</sub> =40mA, ΔV <sub>OUT</sub> =2%	-	100	-	mV
I <sub>SS</sub>	Current Consumption	4.8V	No load	-	2.0	3.0	μA
$\frac{\Delta V_{OUT}}{\Delta V_{IN} \times V_{OUT}}$	Line Regulation	-	3.8V ≤ V <sub>IN</sub> ≤ 12V I <sub>OUT</sub> =40mA	-	0.2	-	%/V
V <sub>IN</sub>	Input Voltage	-	-	-	-	24	V
$\frac{\Delta V_{OUT}}{\Delta T_a}$	Temperature Coefficient	4.8V	I <sub>OUT</sub> =10mA -40°C < T <sub>a</sub> < 85°C	-	±0.5	-	mV/°C

Note: Dropout voltage is defined as the input voltage minus the output voltage that produces a 2% change in the output voltage from the value at V<sub>IN</sub> = V<sub>OUT</sub>+1V with a fixed load.

### HE7330Sxx, +3.0V Output Type

Symbol	Parameter	Test Conditions		Min.	Typ.	Max.	Unit
		V <sub>IN</sub>	Conditions				
V <sub>OUT</sub>	Output Voltage	5V	I <sub>OUT</sub> =40mA	2.94	3.00	3.06	V
I <sub>OUT</sub>	Output Current	5V	-	-	300	-	mA
ΔV <sub>OUT</sub>	Load Regulation	5V	1mA ≤ I <sub>OUT</sub> ≤ 80mA	-	45	90	mV
V <sub>DIF</sub>	Voltage Drop(Note)	-	I <sub>OUT</sub> =40mA, ΔV <sub>OUT</sub> =2%	-	100	-	mV
I <sub>SS</sub>	Current Consumption	5V	No load	-	2.0	3.0	μA
$\frac{\Delta V_{OUT}}{\Delta V_{IN} \times V_{OUT}}$	Line Regulation	-	4V ≤ V <sub>IN</sub> ≤ 12V I <sub>OUT</sub> =40mA	-	0.2	-	%/V
V <sub>IN</sub>	Input Voltage	-	-	-	-	24	V
$\frac{\Delta V_{OUT}}{\Delta T_a}$	Temperature Coefficient	5V	I <sub>OUT</sub> =40mA -40°C < T <sub>a</sub> < 85°C	-	±0.5	-	mV/°C

Note: Dropout voltage is defined as the input voltage minus the output voltage that produces a 2% change in the output voltage from the value at V<sub>IN</sub> = V<sub>OUT</sub>+1V with a fixed load.

### HE7333Sxx, +3.3V Output Type

Symbol	Parameter	Test Conditions		Min.	Typ.	Max.	Unit
		V <sub>IN</sub>	Conditions				
V <sub>OUT</sub>	Output Voltage	5.3V	I <sub>OUT</sub> =40mA	3.234	3.300	3.366	V
I <sub>OUT</sub>	Output Current	5.3V	-	-	300	-	mA
ΔV <sub>OUT</sub>	Load Regulation	5.3V	1mA ≤ I <sub>OUT</sub> ≤ 80mA	-	45	90	mV
V <sub>DIF</sub>	Voltage Drop(Note)	-	I <sub>OUT</sub> =40mA, ΔV <sub>OUT</sub> =2%	-	100	-	mV
I <sub>SS</sub>	Current Consumption	5.3V	No load	-	2.0	3.0	μA
$\frac{\Delta V_{OUT}}{\Delta V_{IN} \times V_{OUT}}$	Line Regulation	-	4.3V ≤ V <sub>IN</sub> ≤ 12V I <sub>OUT</sub> =40mA	-	0.2	-	%/V
V <sub>IN</sub>	Input Voltage	-	-	-	-	24	V
$\frac{\Delta V_{OUT}}{\Delta T_a}$	Temperature Coefficient	5.3V	I <sub>OUT</sub> =40mA -40°C < T <sub>a</sub> < 85°C	-	±0.5	-	mV/°C

Note: Dropout voltage is defined as the input voltage minus the output voltage that produces a 2% change in the output voltage from the value at V<sub>IN</sub> = V<sub>OUT</sub>+1V with a fixed load.

### HE7336Sxx, +3.6V Output Type

Symbol	Parameter	Test Conditions		Min.	Typ.	Max.	Unit
		V <sub>IN</sub>	Conditions				
V <sub>OUT</sub>	Output Voltage	5.6V	I <sub>OUT</sub> =40mA	3.528	3.600	3.672	V
I <sub>OUT</sub>	Output Current	5.6V	-	-	300	-	mA
ΔV <sub>OUT</sub>	Load Regulation	5.6V	1mA ≤ I <sub>OUT</sub> ≤ 80mA	-	45	90	mV
V <sub>DIF</sub>	Voltage Drop(Note)	-	I <sub>OUT</sub> =40mA, ΔV <sub>OUT</sub> =2%	-	80	-	mV
I <sub>SS</sub>	Current Consumption	5.6V	No load	-	2.0	3.0	μA
$\frac{\Delta V_{OUT}}{\Delta V_{IN} \times V_{OUT}}$	Line Regulation	-	4.6V ≤ V <sub>IN</sub> ≤ 12V I <sub>OUT</sub> =40mA	-	0.2	-	%/V
V <sub>IN</sub>	Input Voltage	-	-	-	-	24	V
$\frac{\Delta V_{OUT}}{\Delta T_a}$	Temperature Coefficient	5.6V	I <sub>OUT</sub> =40mA -40°C < T <sub>a</sub> < 85°C	-	±0.5	-	mV/°C

Note: Dropout voltage is defined as the input voltage minus the output voltage that produces a 2% change in the output voltage from the value at V<sub>IN</sub> = V<sub>OUT</sub>+1V with a fixed load.

### HE7340Sxx, +4.0V Output Type

Symbol	Parameter	Test Conditions		Min.	Typ.	Max.	Unit
		V <sub>IN</sub>	Conditions				
V <sub>OUT</sub>	Output Voltage	6.0V	I <sub>OUT</sub> =40mA	3.920	4.000	4.080	V
I <sub>OUT</sub>	Output Current	6.0V	-	-	300	-	mA
ΔV <sub>OUT</sub>	Load Regulation	6.0V	1mA ≤ I <sub>OUT</sub> ≤ 80mA	-	45	90	mV
V <sub>DIF</sub>	Voltage Drop(Note)	-	I <sub>OUT</sub> =40mA, ΔV <sub>OUT</sub> =2%	-	80	-	mV
I <sub>SS</sub>	Current Consumption	6.0V	No load	-	2.0	3.0	μA
$\frac{\Delta V_{OUT}}{\Delta V_{IN} \times V_{OUT}}$	Line Regulation	-	5V ≤ V <sub>IN</sub> ≤ 12V I <sub>OUT</sub> =40mA	-	0.2	-	%/V
V <sub>IN</sub>	Input Voltage	-	-	-	-	24	V
$\frac{\Delta V_{OUT}}{\Delta T_a}$	Temperature Coefficient	6.0V	I <sub>OUT</sub> =40mA -40°C < T <sub>a</sub> < 85°C	-	±0.5	-	mV/°C

Note: Dropout voltage is defined as the input voltage minus the output voltage that produces a 2% change in the output voltage from the value at V<sub>IN</sub> = V<sub>OUT</sub>+1V with a fixed load.

### HE7344Sxx, +4.4V Output Type

Symbol	Parameter	Test Conditions		Min.	Typ.	Max.	Unit
		V <sub>IN</sub>	Conditions				
V <sub>OUT</sub>	Output Voltage	6.4V	I <sub>OUT</sub> =40mA	4.312	4.400	4.488	V
I <sub>OUT</sub>	Output Current	6.4V	-	-	300	-	mA
ΔV <sub>OUT</sub>	Load Regulation	6.4V	1mA ≤ I <sub>OUT</sub> ≤ 80mA	-	45	90	mV
V <sub>DIF</sub>	Voltage Drop(Note)	-	I <sub>OUT</sub> =40mA, ΔV <sub>OUT</sub> =2%	-	80	-	mV
I <sub>SS</sub>	Current Consumption	6.4V	No load	-	2.0	3.0	μA
$\frac{\Delta V_{OUT}}{\Delta V_{IN} \times V_{OUT}}$	Line Regulation	-	5.4V ≤ V <sub>IN</sub> ≤ 12V I <sub>OUT</sub> =40mA	-	0.2	-	%/V
V <sub>IN</sub>	Input Voltage	-	-	-	-	24	V
$\frac{\Delta V_{OUT}}{\Delta Ta}$	Temperature Coefficient	6.4V	I <sub>OUT</sub> =40mA -40°C < Ta < 85°C	-	±0.5	-	mV/°C

Note: Dropout voltage is defined as the input voltage minus the output voltage that produces a 2% change in the output voltage from the value at V<sub>IN</sub> = V<sub>OUT</sub>+1V with a fixed load.

### HE7350Sxx, +5.0V Output Type

Symbol	Parameter	Test Conditions		Min.	Typ.	Max.	Unit
		V <sub>IN</sub>	Conditions				
V <sub>OUT</sub>	Output Voltage	7V	I <sub>OUT</sub> =40mA	4.9	5.00	5.1	V
I <sub>OUT</sub>	Output Current	7V	-	-	300	-	mA
ΔV <sub>OUT</sub>	Load Regulation	7V	1mA ≤ I <sub>OUT</sub> ≤ 80mA	-	45	90	mV
V <sub>DIF</sub>	Voltage Drop(Note)	-	I <sub>OUT</sub> =40mA, ΔV <sub>OUT</sub> =2%	-	80	-	mV
I <sub>SS</sub>	Current Consumption	7V	No load	-	2.0	3.0	μA
$\frac{\Delta V_{OUT}}{\Delta V_{IN} \times V_{OUT}}$	Line Regulation	-	6V ≤ V <sub>IN</sub> ≤ 12V I <sub>OUT</sub> =40mA	-	0.2	-	%/V
V <sub>IN</sub>	Input Voltage	-	-	-	-	24	V
$\frac{\Delta V_{OUT}}{\Delta Ta}$	Temperature Coefficient	7V	I <sub>OUT</sub> =40mA -40°C < Ta < 85°C	-	±0.5	-	mV/°C

Note: Dropout voltage is defined as the input voltage minus the output voltage that produces a 2% change in the output voltage from the value at V<sub>IN</sub> = V<sub>OUT</sub>+1V with a fixed load.

### MAX Output Current Vs. Input Voltage

#### HE7330SPR

Input Voltage	Max Output Current
5V	300mA
9V	200mA
12V	150mA
15V	100mA

#### HE7333SPR

Input Voltage	Max Output Current
5.3V	300mA
9V	200mA
12V	150mA
15V	100mA

#### HE7350SPR

Input Voltage	Max Output Current
7V	300mA
9V	200mA
12V	150mA
15V	100mA

## Application Circuits

### Basic Circuits

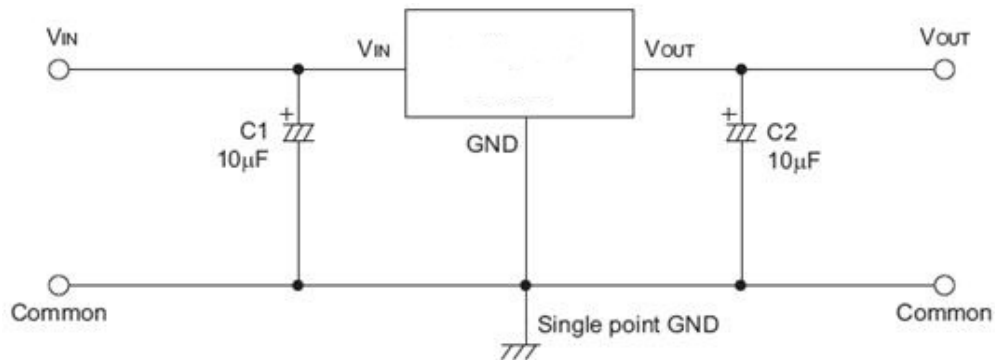

**Package Information**  
**3-pin TO92 Outline Dimensions**

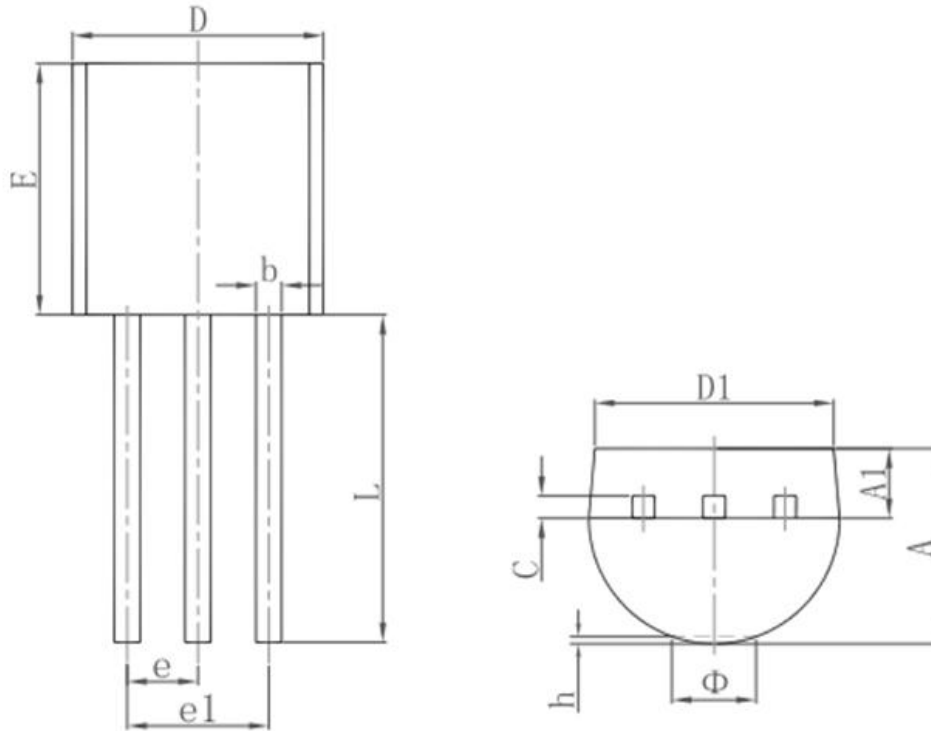

Symbol	Dimensions In Millimeters		Dimensions In Inches	
	Min.	Max.	Min.	Max.
A	3.300	3.700	0.130	0.146
A1	1.100	1.400	0.043	0.055
b	0.380	0.550	0.015	0.022
c	0.360	0.510	0.014	0.020
D	4.300	4.700	0.169	0.185
D1	3.430		0.135	
E	4.300	4.700	0.169	0.185
e	1.270 TYP.		0.050 TYP.	
e1	2.440	2.640	0.096	0.104
L	14.100	14.500	0.555	0.571
$\Phi$		1.600		0.063
h	0.000	0.380	0.000	0.015



**3-pin SOT89 Outline Dimensions**

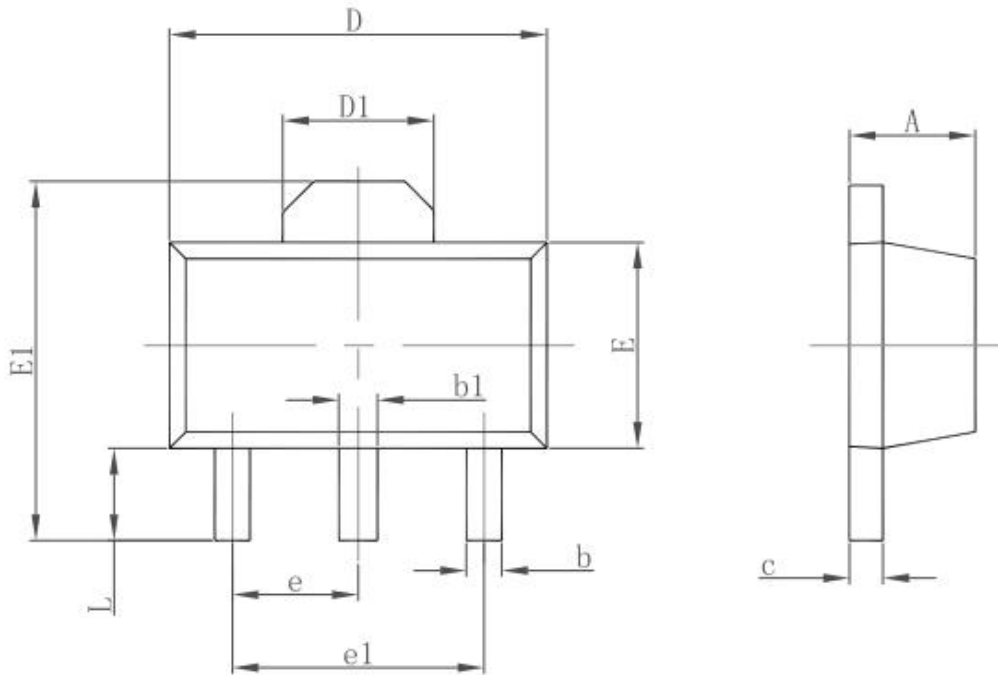

Symbol	Dimensions In Millimeters		Dimensions In Inches	
	Min.	Max.	Min.	Max.
A	1.400	1.600	0.055	0.063
b	0.320	0.520	0.013	0.020
b1	0.400	0.580	0.016	0.023
c	0.350	0.440	0.014	0.017
D	4.400	4.600	0.173	0.181
D1	1.550 REF.		0.061 REF.	
E	2.300	2.600	0.091	0.102
E1	3.940	4.250	0.155	0.167
e	1.500 TYP.		0.060 TYP.	
e1	3.000 TYP.		0.118 TYP.	
L	0.900	1.200	0.035	0.047

### 3-pin SOT23-3 Outline Dimensions

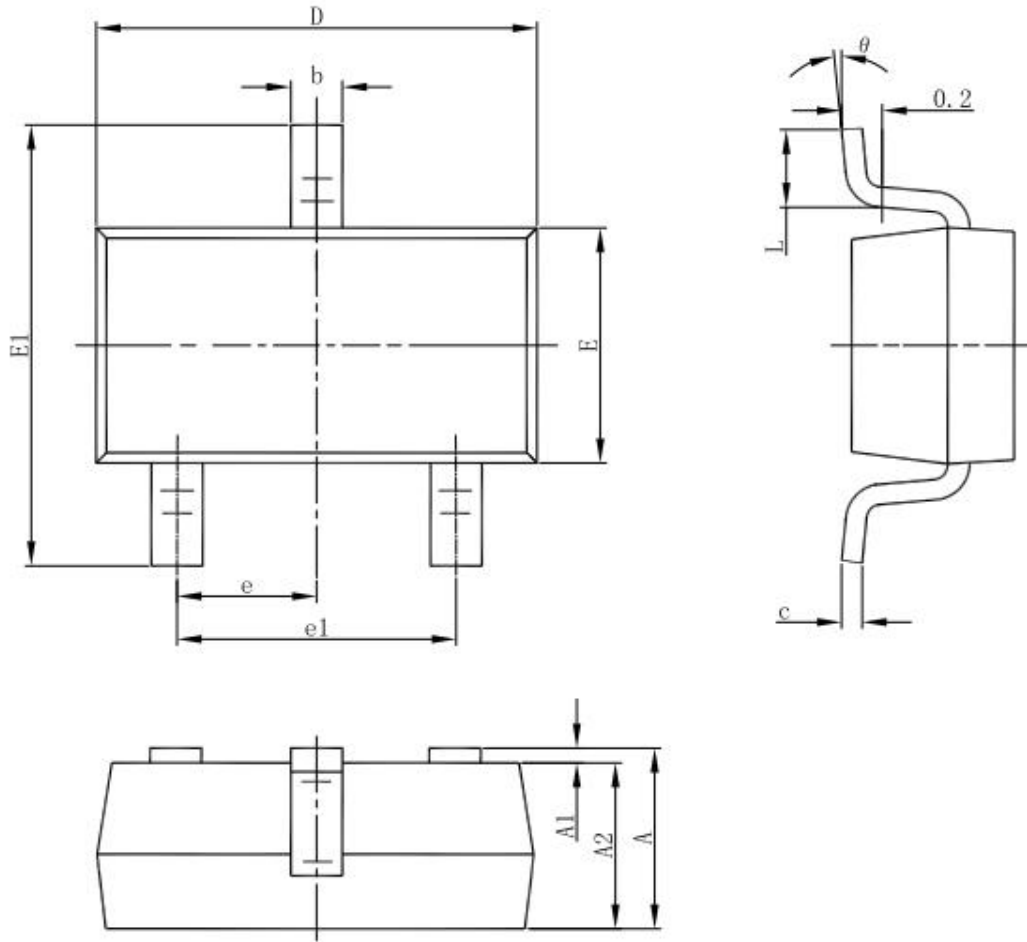

Symbol	Dimensions In Millimeters		Dimensions In Inches	
	Min	Max	Min	Max
A	1.050	1.250	0.041	0.049
A1	0.000	0.100	0.000	0.004
A2	1.050	1.150	0.041	0.045
b	0.300	0.500	0.012	0.020
c	0.100	0.200	0.004	0.008
D	2.820	3.020	0.111	0.119
E	1.500	1.700	0.059	0.067
E1	2.650	2.950	0.104	0.116
e	0.950(BSC)		0.037(BSC)	
e1	1.800	2.000	0.071	0.079
L	0.300	0.600	0.012	0.024
θ	0°	8°	0°	8°

### 3-pin SOT23 Outline Dimensions

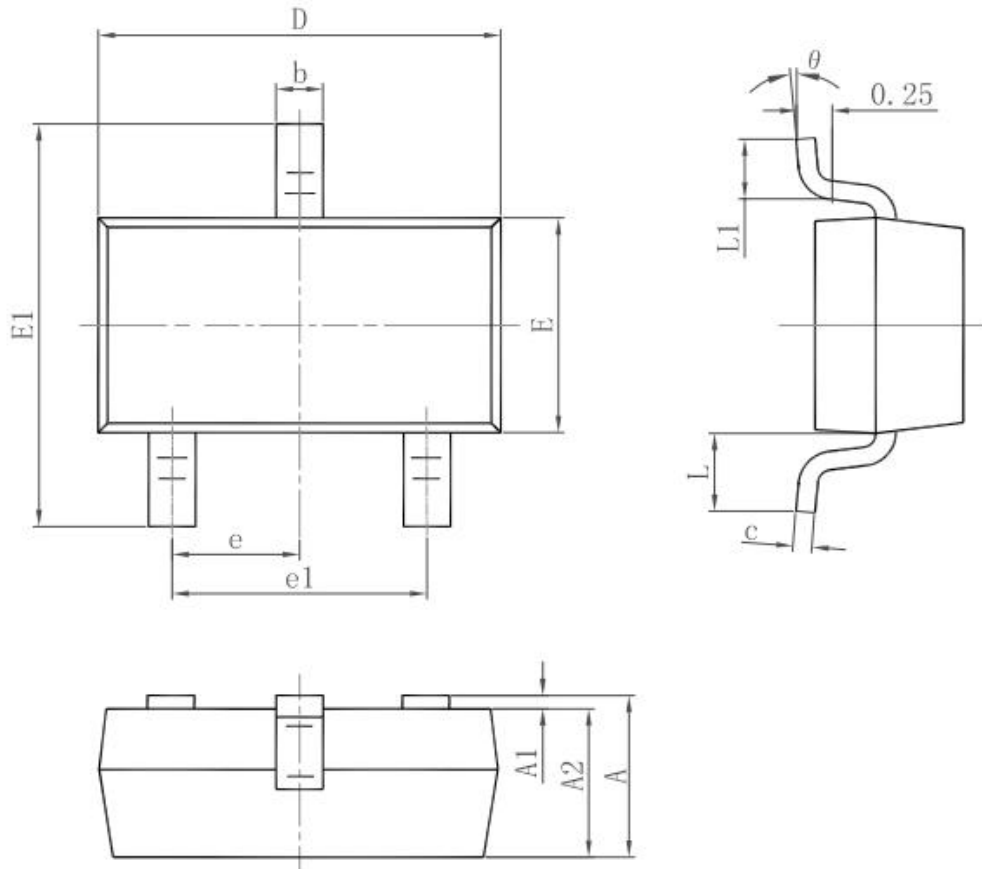

Symbol	Dimensions In Millimeters		Dimensions In Inches	
	Min.	Max.	Min.	Max.
A	0.900	1.150	0.035	0.045
A1	0.000	0.100	0.000	0.004
A2	0.900	1.050	0.035	0.041
b	0.300	0.500	0.012	0.020
c	0.080	0.150	0.003	0.006
D	2.800	3.000	0.110	0.118
E	1.200	1.400	0.047	0.055
E1	2.250	2.550	0.089	0.100
e	0.950 TYP.		0.037 TYP.	
e1	1.800	2.000	0.071	0.079
L	0.550 REF.		0.022 REF.	
L1	0.300	0.500	0.012	0.020
theta	0°	8°	0°	8°

**Product Tape and Reel Specifications**  
**3-pin TO92 Reel Dimensions (Unit: mm)**

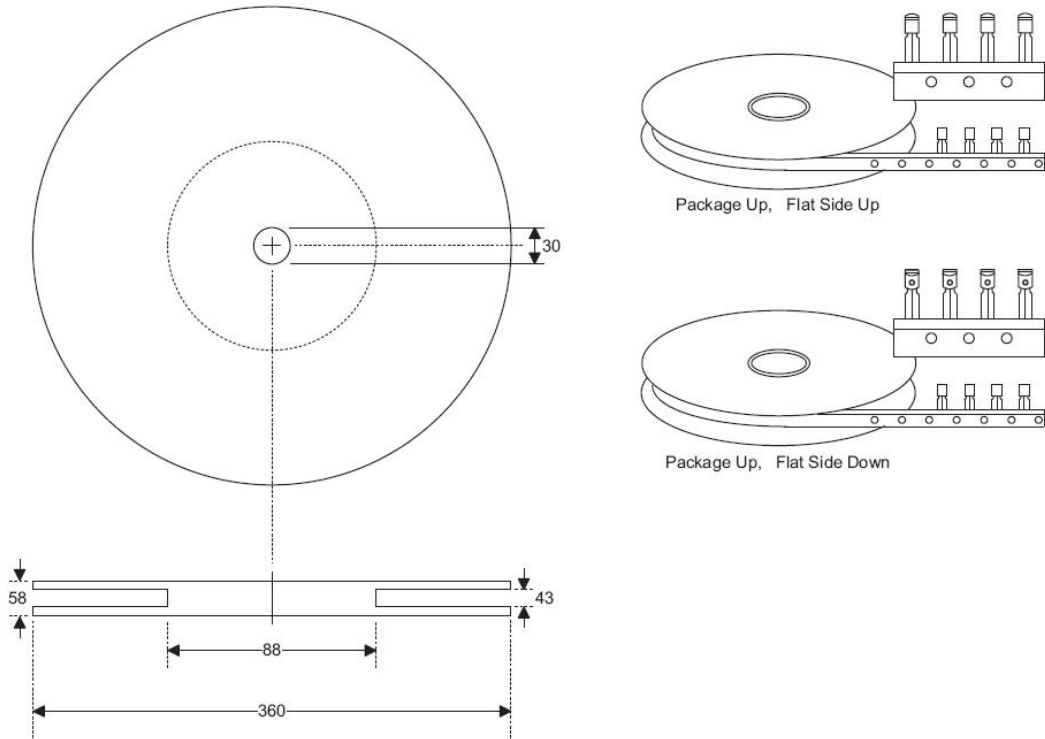

### Reel Dimensions

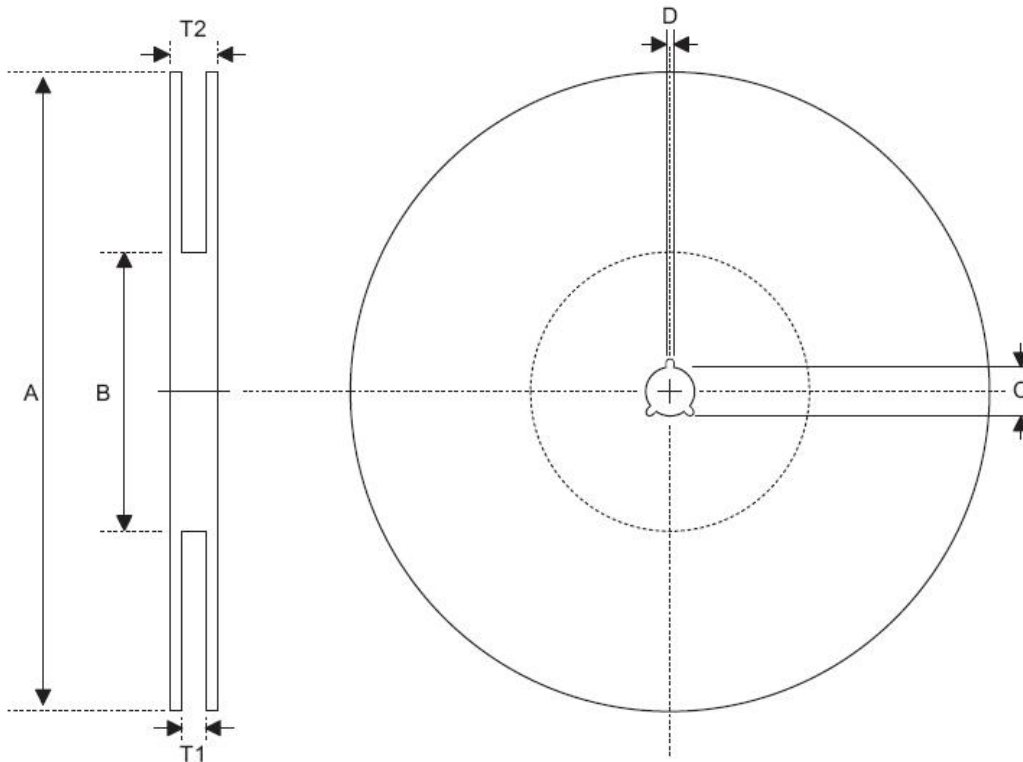

#### SOT89

Symbol	Description	Dimensions in mm
A	Reel Outer Diameter	180.0±1.0
B	Reel Inner Diameter	62.0±1.5
C	Spindle Hole Diameter	12.75 <sup>+0.15/-0.00</sup>
D	Key Slit Width	1.90±0.15
T1	Space Between Flange	12.4 <sup>+0.2/-0.00</sup>
T2	Reel Thickness	17.0 <sup>+0.0/-0.4</sup>

#### SOT23-5

Symbol	Description	Dimensions in mm
A	Reel Outer Diameter	178.0±1.0
B	Reel Inner Diameter	62.0±1.0
C	Spindle Hole Diameter	13.0±0.2
D	Key Slit Width	2.50±0.25
T1	Space Between Flange	8.4 <sup>+1.5/-0.0</sup>
T2	Reel Thickness	11.4 <sup>+1.5/-0.0</sup>

### Carrier Tape Dimensions

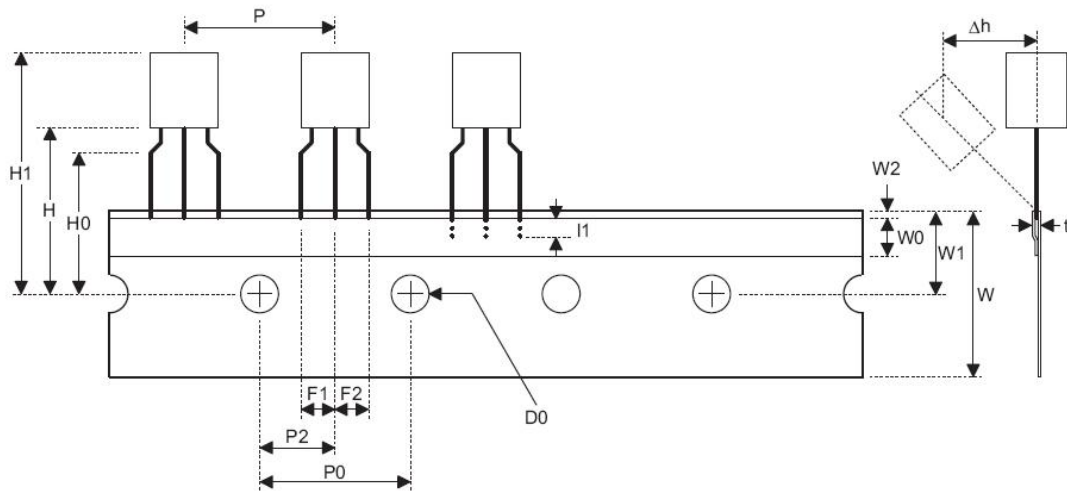

TO92

Symbol	Description	Dimensions in mm
I1	Taped Lead Length	(2.5)
P	Component Pitch	12.7±1.0
P <sub>0</sub>	Perforation Pitch	12.7±0.3
P <sub>2</sub>	Component to Perforation (Length Direction)	6.35±0.40
F <sub>1</sub>	Lead Spread	2.5 <sup>+0.4/-0.1</sup>
F <sub>2</sub>	Lead Spread	2.5 <sup>+0.4/-0.1</sup>
Δh	Component Alignment	0.0±0.1
W	Carrier Tape Width	18.0 <sup>+1.0/-0.5</sup>
W <sub>0</sub>	Hold-down Tape Width	6.0±0.5
W <sub>1</sub>	Perforation Position	9.0±0.5
W <sub>2</sub>	Hold-down Tape Position	(0.5)
H <sub>0</sub>	Lead Clinch Height	16.0±0.5
H <sub>1</sub>	Component Height	Less than 24.7
D <sub>0</sub>	Perforation Diameter	4.0±0.2
t	Taped Lead Thickness	0.7±0.2
H	Component Base Height	19.0±0.5

Note: Thickness less than 0.38\_0.05mm~0.5mm

P0 Accumulated pitch tolerance: \_1mm/20pitches.

( ) Bracketed figures are for consultation only

### Carrier Tape Dimensions

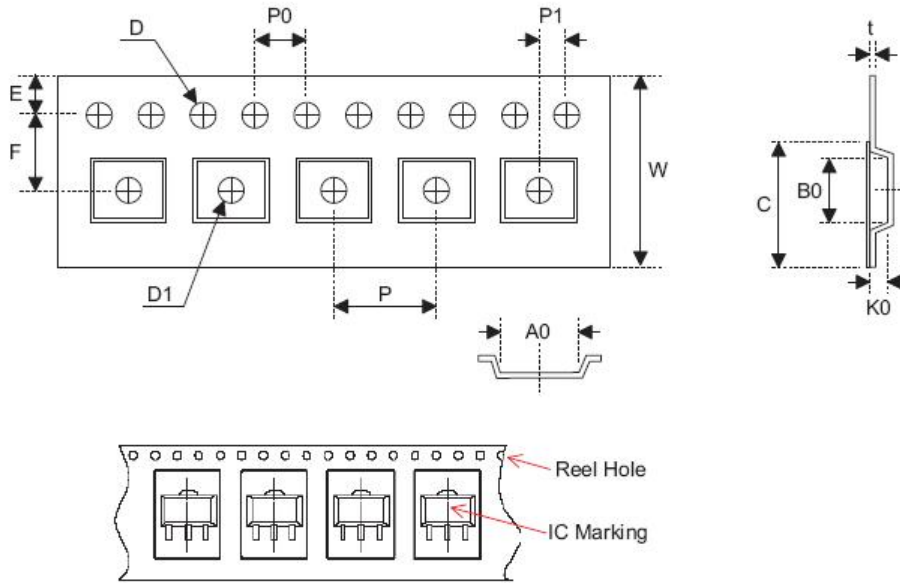

### SOT89

Symbol	Description	Dimensions in mm
W	Carrier Tape Width	12.0 <sup>+0.3/-0.1</sup>
P	Cavity Pitch	8.0±0.1
E	Perforation Position	1.75±0.10
F	Cavity to Perforation (Width Direction)	5.50±0.05
D	Perforation Diameter	1.5 <sup>+0.1/-0.0</sup>
D1	Cavity Hole Diameter	1.5 <sup>+0.1/-0.0</sup>
P0	Perforation Pitch	4.0±0.1
P1	Cavity to Perforation (Length Direction)	2.0±0.1
A0	Cavity Length	4.8±0.1
B0	Cavity Width	4.5±0.1
K0	Cavity Depth	1.8±0.1
t	Carrier Tape Thickness	0.300±0.013
C	Cover Tape Width	9.3±0.1

### SOT23-5

Symbol	Description	Dimensions in mm
W	Carrier Tape Width	8.0±0.3
P	Cavity Pitch	4.0±0.1
E	Perforation Position	1.75±0.10
F	Cavity to Perforation (Width Direction)	3.50±0.05
D	Perforation Diameter	1.5 <sup>+0.1/-0.0</sup>
D1	Cavity Hole Diameter	1.5 <sup>+0.1/-0.0</sup>
P0	Perforation Pitch	4.0±0.1
P1	Cavity to Perforation (Length Direction)	2.00±0.05
A0	Cavity Length	3.15±0.10
B0	Cavity Width	3.2±0.1
K0	Cavity Depth	1.4±0.1
t	Carrier Tape Thickness	0.20±0.03
C	Cover Tape Width	5.3±0.1